

# CREATION & DESIGN

PROFILE, FINISHING, MOULDING, CENTER PANEL  
WOOD TYPE, GRADE, ACCESSORY, OPTION



caron®

Thinks wood, thinks green

# 2020



# CARON THINKS GREEN

**FROM NATURE... WOOD, A LIVING AND NOBLE MATERIAL IS ESSENTIAL TO THE CHARACTER OF OUR PRODUCTS. WOOD IS ALSO PART OF OUR COLLECTIVE HERITAGE. THIS IS WHY CARON IS RESPECTFUL OF THE ENVIRONMENT BY OPTIMIZING THE USE OF THIS PRECIOUS NATURAL RESOURCE AND BY REFORESTING EVERY YEAR MORE TREES THAN THE COMPANY USES, A PREMIERE IN THE INDUSTRY SINCE 2005.**

WELCOME TO CARON'S WORLD, WHERE YOU WILL FIND ONE OF THE MOST EXTENSIVE LINE OF CABINET DOORS AVAILABLE ON THE MARKET AND MUCH MORE. AT CARON, WE KNOW THAT NOTHING HIGHLIGHTS QUALITY CABINETRY MORE THAN BEAUTIFULLY CRAFTED DOORS. OUR QUALITY MANAGEMENT SYSTEM REGISTERED UNDER ISO 9001 GUARANTEES THAT EACH COMPONENT MEETS THE HIGHEST STANDARDS OF QUALITY BEFORE IT BEARS THE CARON SIGNATURE.



# TABLE OF CONTENTS

20-1200-1-20-03-508-F54-P97

Proud partner since 2005



Wood type / Grade / Sanding	4
Authentic	7
Barn	9
Center panel profile	10
Interior moulding	11
Exterior profile / holes for hinges	11
Shaker	12
ECO series	14
Option / Open frame	15
Option / Center panel (applied moulding)	20
Option / Center panel (routing, environment)	23
Option / Stile and rail (applied moulding and routing)	30
Multi panel door / Wainscot	33
Finishing / holes for hinges	38
Medium density fiberboard (MDF)	42
Laminated MDF (Euro Lam)	46
<b>Specialty component</b>	
Hi Gloss (Brilliant)	48
Euro / Euro+ / Euro <sup>3</sup>	50
Engineered (Exotik)	53
Textured door:	
- Versa	54
- Mosaik	56
- Ocean	57
Torrified	59
Curved	60
Vaulted applique, angled	62
Appliance panel / Face frame	64
<b>Moulding</b>	66
<b>Accessory</b>	
Architectural wood carving	70
Laminated wood surface	72
Dovetail drawer box	74
End gable / Edge band	76
Fret work	76
Valance	76
Wood turning	76
Pilaster / filler	76
<b>Promotional support</b>	77
<b>Code description / How to order / On line</b>	78
<b>General information</b>	81
<b>Guarantee</b>	82



# GRADE AND SANDING

**WOOD IS WONDERFUL... FROM ONE SPECIES TO ANOTHER THERE IS AN INFINITE VARIETY OF COLORS, GRAIN PATTERNS AND PARTICULARITIES. MOREOVER, WITHIN THE SAME SPECIES NO TWO BOARDS ARE IDENTICAL JUST AS NO TWO TREES ARE ALIKE. ENVIRONMENTAL FACTORS SUCH AS CLIMATE, LIGHT EXPOSURE, RAINFALL AND MINERAL CONTENT OF THE SOIL, TO NAME JUST A FEW, CAUSE THESE VARIATIONS.**

Most of our components are made from hardwoods harvested in the northern Appalachians, a region renowned for its quality timber and reforestation that ensures the continued protection of this heritage.

As people are becoming more and more concerned about environmental issues, and rightly so, each of us must optimize the use of this renewable, but highly precious resource. We invite you to take the time to thoughtfully choose the type and grade of lumber needed, to ensure the enduring value of your project crafted from this precious resource. Medium to dark or glazed finishes lend themselves well to SELECT or RUSTIC grades. SELECT PLUS grade is favoured for bleached and natural finished which require painstaking color matching. KNOTTY RUSTIC grade is for unconditional wood lovers who appreciate all particularities, lots of character and life.

The following list and pictures are not exhaustive and other types of wood are available on demand. Should any doubts concerning a type or grade of wood persist, we suggest you order our new wood selection and / or a sample door before the complete order.



## GRADE / FACE (Back + edges not selected for color and natural particularities accepted)

WOOD TYPE	RUSTIC (listed prices less 10%)	KNOTTY RUSTIC (listed prices)	SELECT (reference grade for listed prices)	SELECT PLUS (listed prices plus 15%)	TORREFIED (listed prices plus 65 %)
<b>ALDER</b> (red) - AR -	N/A	Natural particularities accepted; color + grain variations. All knots structurally sound accepted.	Natural particularities accepted; reddish color.	N/A	N/A
<b>ASH</b> (white) - F -	Same as select, not selected for color. Mineral + occasional light crazing accepted.	Same as rustic grade with knots without restriction.	Natural particularities accepted; Burls, pin knots, wide range of cream to light brown colors.	Same as select with more color uniformity	Same as select grade with dark brown color created by the roasting process.
<b>BAMBOO</b> - BA -	N/A	N/A	Natural particularities accepted. Close, straightgrain. Light cream color and occasional darker streaks.	N/A	Natural particularities accepted. Close, straight grain. Golden color with light brown streaks created by the roasting process.
<b>BIRCH</b> (red) - U -	Same as select, not selected for color. Mineral + occasional light crazing accepted	Same as rustic grade with knots without restriction.	Natural particularities accepted. Out of heartwood only, reddish color with attractive grain.	N/A	N/A
<b>BIRCH</b> (yellow) - M -	Not selected for color. Mineral + occasional light crazing accepted.	Same as rustic grade with knots without restriction.	Natural particularities accepted. Out of sap wood only, light and fairly uniform in color and grain.	Same as select with more color uniformity.	Natural particularities accepted. Heartwood and sapwood, brown to dark brown color created by the roasting process.
<b>CHERRY</b> - I -	Same as select, not selected for color. Mineral + occasional light crazing accepted. (listed prices -15%)	Same as rustic grade with knots without restriction.	Natural particularities accepted. Gum lines, gum pockets, limited sap wood (max. 20% of front surface).	Same as select with fewer particularities and no sap wood on the face [Except for machined areas]	N/A
<b>FIR</b> (B.C.) - S -	N/A	N/A	Natural particularities accepted. Reddish color, some sap wood.	Natural particularities accepted with more color uniformity	N/A
<b>HICKORY</b> (wild) - H -	N/A	Same as select grade with knots without restriction.	Natural particularities accepted; Wild and wide range of colors (sap and heart wood) not selected for color.	N/A	N/A
<b>MAHOGANY</b> - A -	N/A	N/A	Natural particularities accepted; Pin knots, burl. Golden brown to reddish color.	N/A	N/A
<b>MAPLE</b> - E -	Not selected for color. Mineral + occasional light crazing accepted.	Same as rustic grade with knots without restriction.	Natural particularities accepted; Light and uniform in color and grain. Some mineral accepted on the face without restrictions on the back and edges.	Same as select with more color uniformity and fewer mineral.	N/A
<b>MAPLE</b> Silver - E S -	N/A	N/A	Natural particularities accepted; Light and uniform in color and grain. Some mineral accepted on the face without restrictions on the back and edges. Light silver tones	N/A	N/A
<b>MAPLE</b> (Wild) - E W -	N/A	N/A	All natural particularities accepted without restrictions and in various proportions. Wide range of colors (heartwood and sapwood) not selected for color.	N/A	N/A
<b>MAPLE</b> (Wormy) - S M W -	Not selected for color. All natural particularities accepted as per worm holes, mineral, etc...	N/A	N/A	N/A	N/A
<b>MDF</b> - R -	N/A	N/A	N/A	Premium fiber, high density.	N/A
<b>OAK</b> (red) - C -	Same as select, not selected for color. Mineral + occasional light crazing accepted.	Same as rustic grade with knots without restriction.	Natural particularities accepted; Pin knots, some mineral on the face without restrictions on the back and edges. Minimal color variations.	Same as select with more color uniformity and fewer mineral.	N/A
<b>OAK</b> (white) - B -	N/A	N/A	Natural particularities accepted; Pin knots, burl, some mineral. Light brown to greenish gray colors.	N/A	N/A
<b>PINE</b> - P -	N/A	Natural particularities accepted; color + grain variations. All knots structurally sound accepted.	N/A	Natural particularities accepted; uniform in color, grain. Knots not accepted. [clear]	Same as knotty rustic with darker color created by the roasting process.
<b>SAPPELE</b> - SA -	N/A	N/A	Natural particularities accepted; Golden brown to reddish color.	N/A	N/A
<b>TEAK</b> - T -	N/A	Same as select grade with knots without restriction.	Natural particularities accepted; High contrast of yellow to dark brown. Oily texture.	N/A	N/A
<b>WALNUT</b> (American Black) - N -	Same as select, not selected for color. Mineral + occasional light crazing accepted.	Same as rustic grade with knots without restriction.	Natural particularities accepted; Light gray brown to dark purplish brown. [swirls, burls]. Limited sap wood (max. 20% of surface)	N/A	N/A

### Grade (others)

• Select silver maple for stain.

**Water salvaged (Birch)**

First growth lumber recuperated from watery surroundings. Tight growth rings, unselected for color with mineral staining.

**Jointed (Maple, birch, walnut as per availabilities. Listed prices Less 10%)**

Optimize natural resources by using shorter wood cuts. Not selected for colors.

### Sanding

High technology providing you with:

- Finish sanding on all surfaces
- De-nibbing on all surfaces
- Cross-grain marks removal (Front + back)
- Packaging with foam between each component

**N.B. Even with this optimal sanding, components shipped unfinished still need a minimum of preparation at your end prior to finishing. This being due to various factors such as handling during packaging and unpacking, hole drilling for hinges, etc. Your light sanding ensures you better finish uniformity on all elements. (doors, end gables, mouldings, trims, etc.)**

# ZEBRAWOOD

CARON WOOD SELECTION COMPLETE RANGE OF NATURALLY UNIQUE WOODS

# NEW WOOD SELECTION

# 50%



OR **FREE** WITH AN ORDER OF  
20 CABINET/FURNITURE DOORS OR MORE\*

## WOOD IS WONDERFUL...

DISCOVER CARON'S EXCLUSIVE SELECTION INCLUDING  
MORE THAN 40 DIFFERENT SOLID WOOD SAMPLES IN A PRACTICAL  
ARCHITECT'S FOLDER.

\*LIMITED TIME OFFER / CONDITIONS MAY APPLY



ALDER (RED) -AR-



BAMBOO -BA-



BIRCH (YELLOW) -M-



DOUGLAS FIR -S-



MAHOGANY -A-



SAPPELE -SA-



MAPLE (WORMY) -SMW-



OAK (WHITE) -B-



TEAK -T-



ASH (WHITE) -F-



BIRCH (RED) -U-



CHERRY -I-



HICKORY (WILD) -H-



MAPLE -E-



SILVER MAPLE -ES-



OAK (RED) -C-



PINE (KNOTTY) -P-



MDF -R-



WALNUT -N-

These pictures are a general representation of a specific wood type and grade. Since nature never duplicates itself, you may notice a slight difference in color and grain from one order to another, between components, even within the same component. We suggest to order a sample door to see first hand prior to ordering complete projects.



# AUTHENTIC STYLE

**NATURAL, RUGGED, HOMEY** CARON'S NEW KNOTTY RUSTIC GRADE WILL CAPTURE YOUR ATTENTION AND IMPRESS YOU WITH ITS UNIQUE CHARACTERISTICS IN SEVERAL WOOD TYPES SUCH AS BLACK WALNUT, CHERRY, HICKORY, RED ALDER, MAPLE, AND MORE. IT'S A PERFECT DOOR FOR THOSE WHO LOVE REAL WOOD!

IN TODAY'S MARKET, KNOTTY PINE IS THE MOST WIDELY KNOWN RUSTIC WOOD. KNOTTY RUSTIC GRADE GOES ONE STEP FURTHER, WHETHER YOU ARE LOOKING FOR LIGHT-COLORED WOOD WITH DISTINCT CONTRAST (SUCH AS MAPLE OR HICKORY), OR DEEPER SHADES WITH SUBTLER CONTRASTS (LIKE BLACK WALNUT, CHERRY, ALDER, ETC.)

KNOTTY IS IDEAL FOR MANY APPLICATIONS: COMPLETE KITCHEN PROJECTS THAT CALL FOR NATURAL WARMTH AND A HOMEY LOOK (FOR COTTAGES, LOFTS, ETC.) OR ONLY PART OF IT, VANITIES, ISLANDS, SPECIALTY FURNITURE.

- AVAILABLE IN MOST WOOD TYPES
- AVAILABLE IN MOST DESIGNS
- OPTIMAL AND ENVIRONMENTALLY FRIENDLY USE OF NATURAL RESOURCES
- **REDUCED FINISHING COST (NO STAIN REQUIRED)**

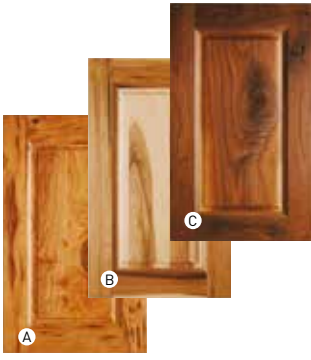

A - 10-1200-I (GR4)-302-01 (3'')-F01  
B - 10-1200-H (GR4)-302-01 (3'')-F01  
C - 10-1200-N (GR4)-302-01 (3'')-F01



Door design :  
 Open frame design :  
 Drawer front design :  
 Valences (toe kick) :  
 Wood type :

Colors :

# 10-1200-ES-197-03-997-F256  
 # 15-1200-ES-03-997-F256  
 # 30-1200-ES-197-03-997-F256  
 # 9750-ES-997-F256  
 Solid maple / Barn  
 Solid quarter cut white oak / Barn  
 # 256, épidor  
 # 128, blé automne







# BARN STYLE

**THE RUGGEDNESS OF THE WOOD CONTRASTS NICELY WITH THE OTHER FINISHES IN YOUR DECOR, WHATEVER YOUR INSPIRATION. WITH CARON-EXCLUSIVE BARN STYLE DOORS AND PANELS FOR CABINETS, MODERN, EXOTIC AND EVEN ECLECTIC DESIGNS ARE COMPLEMENTED WITH WARMTH AND AUTHENTICITY.**

THERE'S NOTHING QUITE LIKE THE BARN STYLE COLLECTION FOR AUTHENTIC CONTRAST, AND IT'S A GREAT OPTION FOR A VARIETY OF APPLICATIONS, INCLUDING CABINET DOORS, FURNITURE, WALL SECTIONS, BACKSPLASHES, ISLAND FRONTS AND WOOD COUNTER EDGES.

- 
**RUGGEDNESS AND WARMTH OF BARN WOOD (OPTION #997) STILL BEARING CUT MARKS ON THE FRONT (STANDARD SANDING ON THE EDGES AND THE BACK)**

**FOR A WEATHERED LOOK, CONSIDER THE DRIFTWOOD OPTION (#990):**

- GIVES A THREE-DIMENSIONAL ASPECT TO THE WOOD GRAIN (STANDARD SANDING ON THE EDGES AND THE BACK) FOR AN AUTHENTIC LOOK THAT IS NATURALLY WEATHERED BY THE ELEMENTS**

AVAILABLE UNFINISHED, WITH NATURAL FINISH OR GLAZED (SEE CARON'S COLOUR SELECTION), THIS IN SEVERAL WOOD TYPES AND DESIGNS

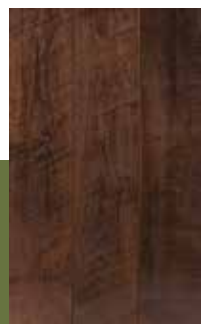

 90-6650-N-~~297~~-F01

 10-1200-N-197-03-~~997~~-F01

 10-1200-ES-197-03-~~997~~-F256

10-1200-ES-197-89-~~993-997~~-F171

20-6500-CQ-458-87-~~990~~-F21

20-1200-CQ-20-03-~~990~~-F533



**DESIGNER COLLECTION**

**50%**



# DESIGNER COLLECTION

**50%**

WHICH ITS PRACTICAL ENVIRONMENTALLY FRIENDLY CARRYING CASE AND CLOSE TO 100 DIFFERENT WOOD/MDF COMPONENTS TO CHOOSE FROM. LIKE NEVER BEFORE, YOU NOW CAN MAKE EXCLUSIVE COMBINATIONS AND PROJECTS.

HAVE EVERYTHING AT HAND WITH THE NEWLY IMPROVED VERSION OF THE CARON DESIGNER COLLECTION. TAKE ADVANTAGE OF OUR OFFER AND GET IT SHIPPED TO YOU WITHIN 24 HOURS AT 50%\* OFF LISTED PRICES.

\* LIMITED TIME OFFER / CONDITIONS MAY APPLY

## PROFILE

### CENTER PANEL

Same letters on different center panels indicates suggested combinations for doors + small drawer fronts.

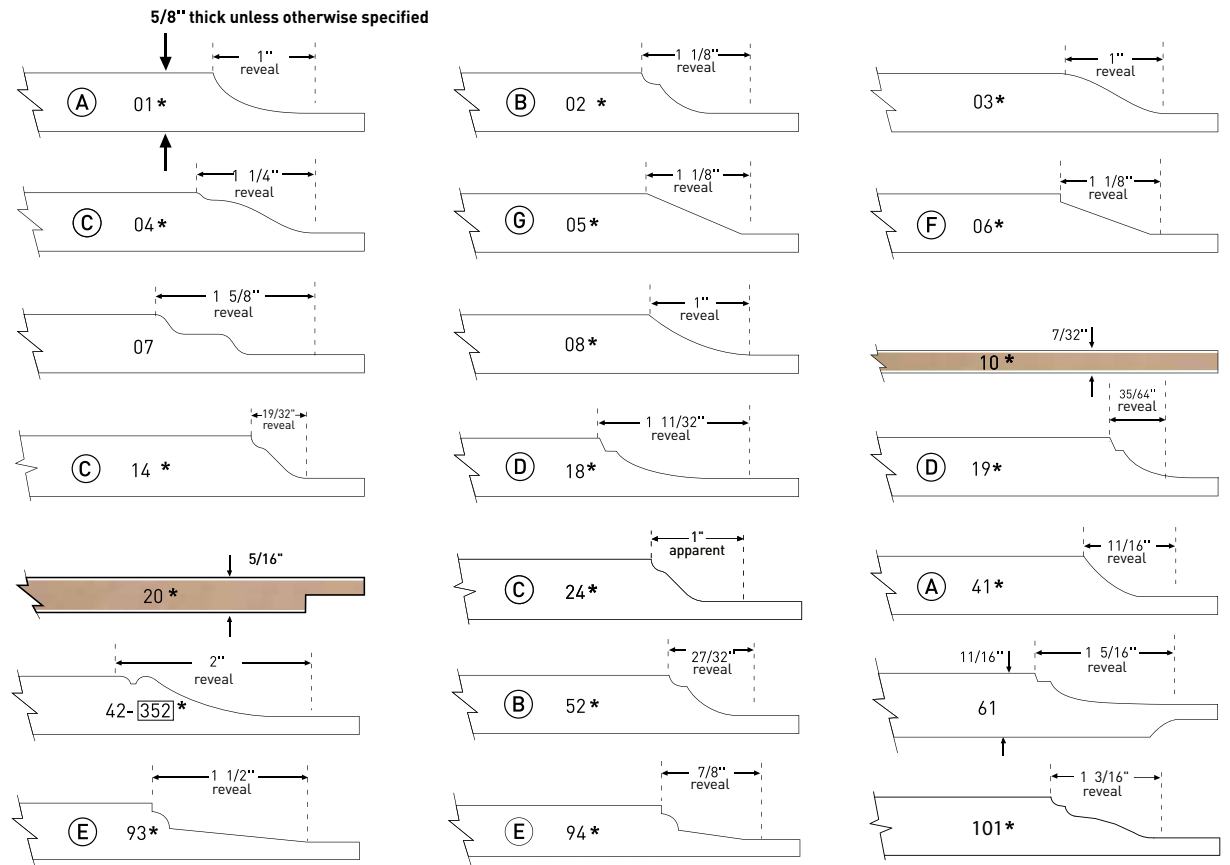

### ECO series

Save 13% with the new optimized solid wood « ECO » series.

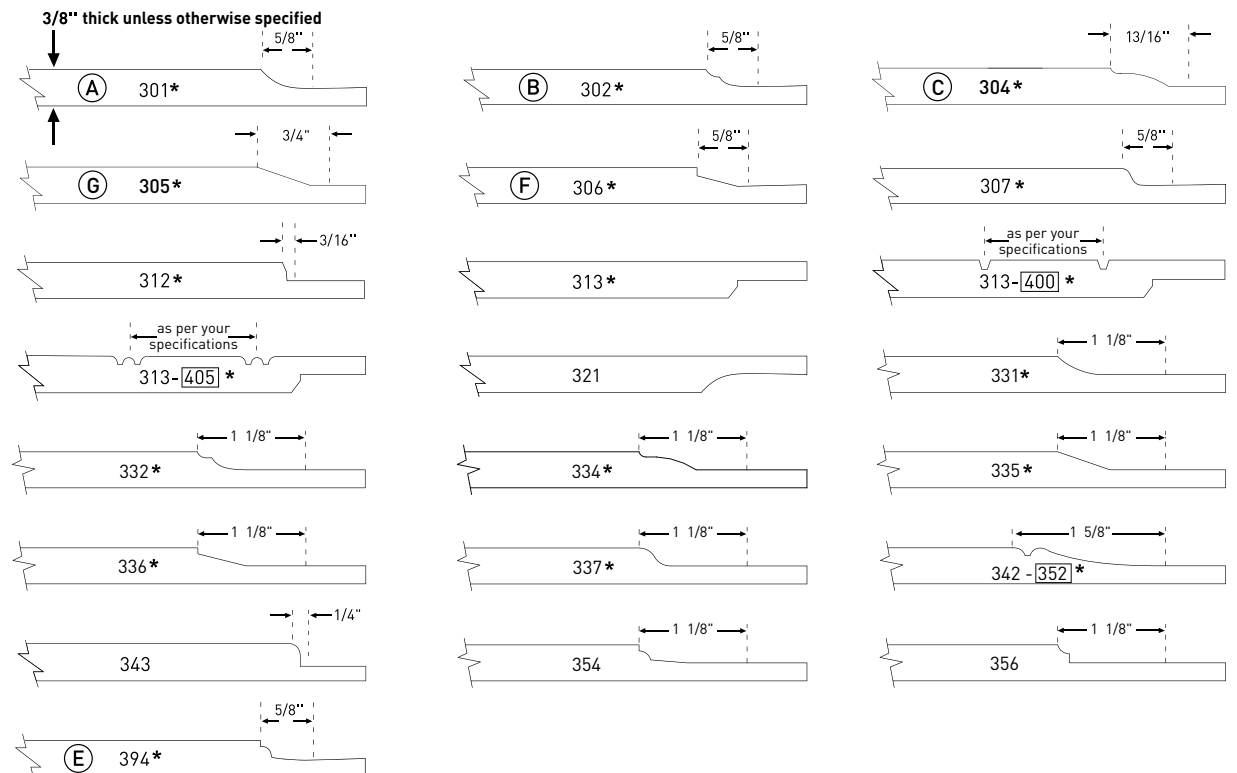

## INTERIOR MOULDING

Some mouldings are available in indicated widths only  
Other mouldings: 2 1/4" standard or as per your specifications.

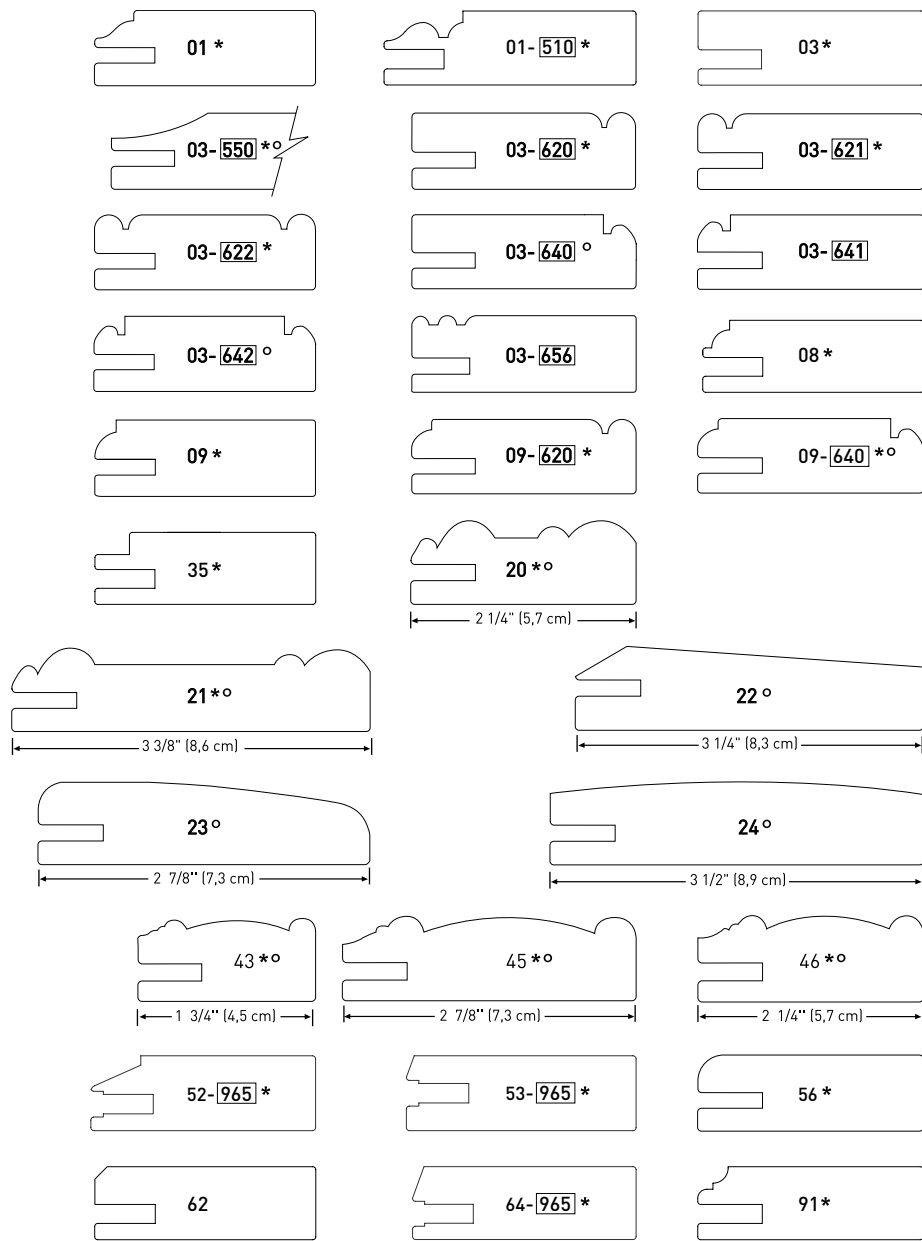

965 = optional groove for stain available on several mouldings

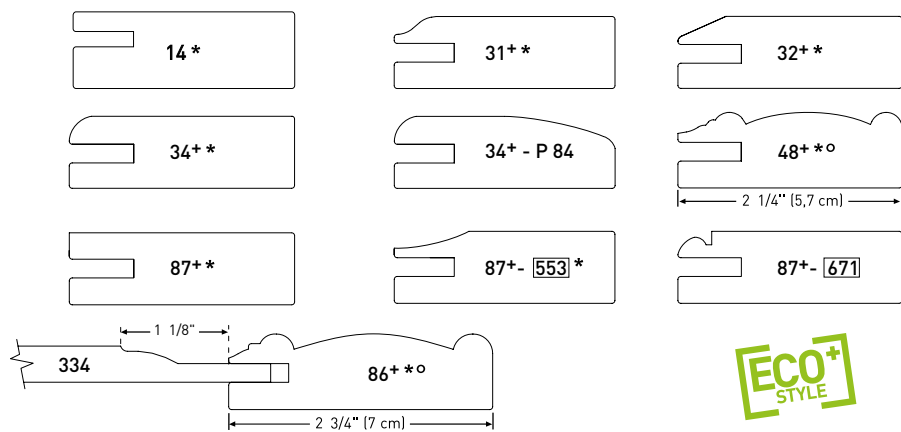

+ Exclusive moulding specifically designed to bring the surface of the solid wood ECO panels up, closer to the surface of the moulding. Ex.: #86 and #334.  
° Mitered construction only. Others 90° and 45° construction.

## EXTERIOR PROFILE

DRILLING FOR HINGES

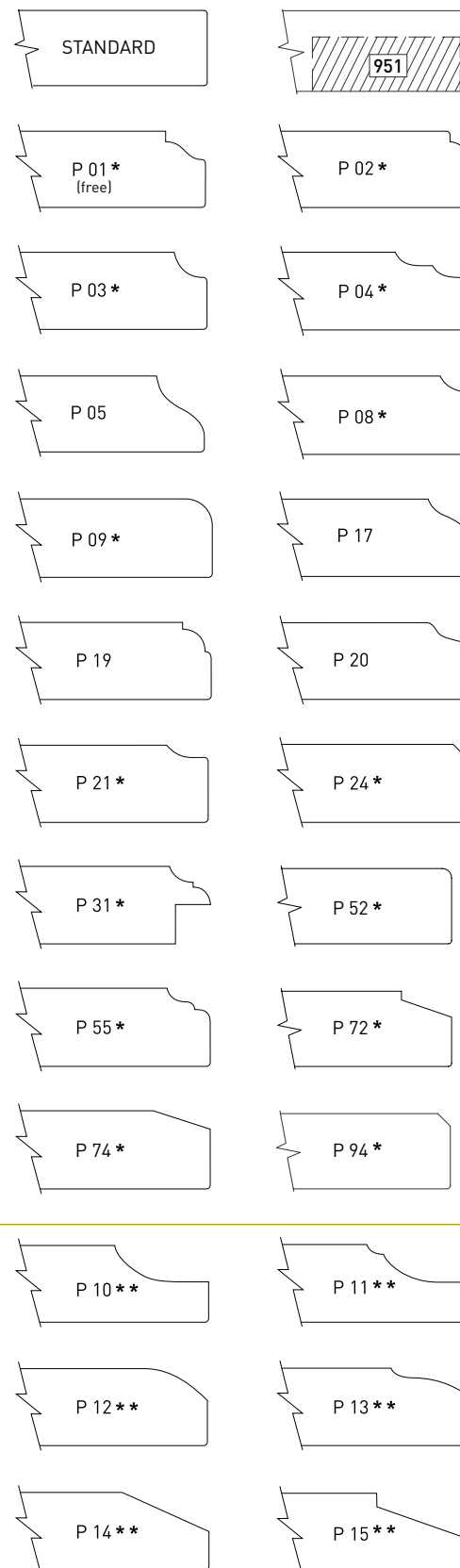

\* Also available in M.D.F.  
\*\* Recommended for 30-6000 series drawer fronts only.

N.B. Drawings in this guide are not to scale.

## CONSTRUCTION TYPES

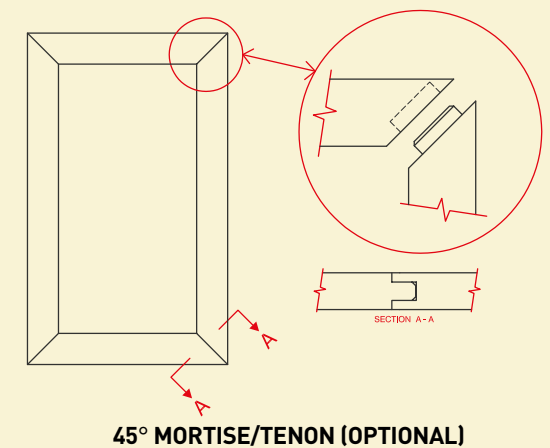
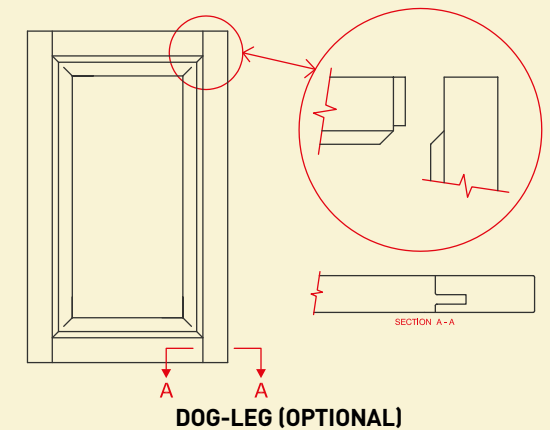
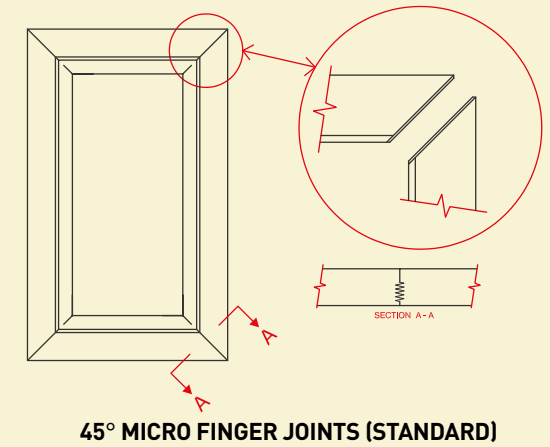
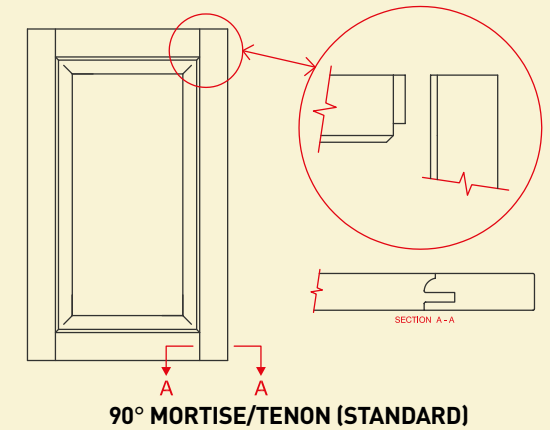

# SHAKER STYLE

## MANCHESTER



1 PIÈCE • 70 - 4100 - R



2 PIÈCES • 75 - 1200 - R - 124 - 168



5 PIÈCES • 10 - 1200\* - R - 98 - 14



5 PIÈCES • 10 - 1200\* - E - 98 - 14



5 PIÈCES • 20 - 1200\* - E - 20 - 14

## ENDFIELD



1 PIÈCE • 70 - 1200 - R - 033



2 PIÈCES • 75 - 1200 - R - 124 - 157



5 PIÈCES • 10 - 4500 - R - 98 - 62



5 PIÈCES • 10 - 1200\* - E - 98 - 62



5 PIÈCES • 20 - 1200\* - E - 20 - 62

## HARVARD



1 PIÈCE • 70 - 1200 - R - 031



2 PIÈCES • 75 - 1200 - R - 124 - 155



5 PIÈCES • 10 - 4500\* - R - 98 - 53



5 PIÈCES • 10 - 1200\* - E - 98 - 53



5 PIÈCES • 20 - 1200\* - E - 20 - 53

## CANTERBURY



1 PIÈCE • 70 - 1200 - R - 046



2 PIÈCES • 75 - 1200 - R - 124 - 170



5 PIÈCES • 10 - 1200\* - R - 98 - 32



5 PIÈCES • 10 - 1200\* - E - 98 - 32



5 PIÈCES • 20 - 1200\* - E - 20 - 32

## SAVOY



1 PIÈCE • 70 - 4050 - R - 009



2 PIÈCES • 75 - 1200 - R - 124 - 160



5 PIÈCES • 10 - 4500 - R - 98 - 35



5 PIÈCES • 10 - 1200\* - E - 98 - 35



5 PIÈCES • 20 - 1200\* - CQ - 20 - 35



# SHAKER STYLE

**WITH THEIR CLEAN, SIMPLE LINES, THE SHAKER STYLE COLLECTION OF CABINET AND FURNITURE DOORS TRANSCEND CURRENT STYLES AND TRENDS. WITH THE SHAKER EVENT, IT'S EASIER THAN EVER TO GET YOUR HANDS ON THIS TRUE CLASSIC. QUALITY AND FAST SERVICE, SIGNED CARON.**

STARTING FROM \$7.55\* NET/SQ. FT., THE SHAKER STYLE COLLECTION IS WELL SUITED FOR ALL DECORS AND ALL BUDGETS. CHOOSE UNFINISHED COMPONENTS, OR SAVE TIME AND MONEY BY SELECTING PREFINISHED OPTIONS IN A RANGE OF ATTRACTIVE COLOURS (OR WITH A PRIMER COAT ONLY ON MDF). FINISHING IS OFFERED STARTING FROM ONLY \$3.97/SQ. FT.

- AVAILABLE IN MDF 1 PIECE, 2 PIECE AND 5 PIECE
- AVAILABLE IN VARIOUS WOOD TYPES EITHER SELECT OR RUSTIC GRADE
- CENTRAL PANEL IN MDF, PLYWOOD OR SOLID WOOD IN VARIOUS THICKNESSES (DEEP, CENTERIZED OR SHALLOW RECESS)
- OPTIMAL PRICE-QUALITY RATIO
- LATEST TECHNOLOGY SANDING



WOOD



MDF



PLYWOOD



Door design : # 20-1200-ES-10-03  
Open frame design : # 15-1200-ES-03  
Drawer front design : # 35-1200-ES-10-03  
Vaulted applique : # 90-8100-ES-10-03  
Wine rack : # 90-2000  
Wood type : Silver maple  
Color : # F131 Blanc design  
# F196 (Island)





**PRESENTING A NEW ALTERNATIVE** IN RAISED AND REVERSE RAISED PANELS THE NEW ECO-STYLE COLLECTION BY CARON. WITH THEIR INNOVATIVE, ENVIRONMENTALLY FRIENDLY DESIGN AND OPTIMAL USE OF NATURAL RESOURCES, THEY'RE SURE TO PLEASE THE MOST CREATIVE CUSTOMERS. THESE DURABLE CENTER PANELS WITH EUROPEAN FLAIR ARE GIVING YOU THE FREEDOM TO OPTIMIZE YOUR PROJECT DESIGN WHILE KEEPING COSTS IN CHECK.

 **UP TO 13% SAVINGS** ON RAISED PANEL DOORS.

- OVER 20 CENTER PANEL SHAPES TO CHOOSE FROM (REF. PAGE 10).
- OPTIMAL AND ENVIRONMENTALLY FRIENDLY USE OF NATURAL RESOURCES.
- SLEEK, SOFT LINES (A COMPROMISE BETWEEN REGULAR RAISED AND RECESSED PANELS).
- EASY+PERFECT MATCH BETWEEN DOORS AND DRAWER FACES. (SAME CENTER PANEL ON BOTH)
- CAN ALSO BE USED FOR DRAWER FRONTS ONLY (IN COMBINATION WITH REGULAR 5/8" THICK CENTER PANELS FOR THE DOORS)



Optimized solid wood  
3/8" Thick ECO panel

Also available in M.D.F.



Standard solid wood  
5/8" Thick panel

Also available in M.D.F.



DESIGN BY 44N

Door design: # 10-1200-ES-321-08-P55  
Open frame design: # 15-1200-ES-00-08-[830]-P55  
Drawer front design: # 30-1200-ES-321-08-P55  
Ogee: # 9800  
Wood type: Solid silver maple  
Color: # 924 Café noir



Caron offers you the most extensive line of open frames for glass. With or without mullions, numerous configurations are available as well as your own designs. Enhance your projects with these exclusive components.



15-3100-M-00-52-000-F52



15-1200-M-00-02-800-F115



15-1200-E-00-09-840-F01



15-3100-E-00-09-840-F34-P02

**OPEN FRAME ONLY** : Available in most designs including clear vinyl strip to hold the glass. Price and design # as per corresponding flat panel door (use group code 15).

**MULLIONS** : Available in most designs including shaker and mitered.



15-1200-T-00-03-825-F01



15-1200-E-00-03-838-F115



15-1200-M-00-03-817-F21

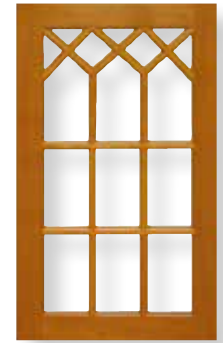

15-1200-M-00-09-831-F34

**GOTHIC SERIES** : Available with framing bead # 03 only. (Restrictions may apply in other series)

<b>RABBET FOR GLASS</b>	moulding #03	moulding #03	moulding #03	moulding #03	moulding #03	moulding #04
<p>N.B. Moulding width – rabbet width = space left for hinges Restrictions may apply according to moulding # ordered</p>						
<b>MULLIONS</b>						
	<p>Caron will use the type of mullion which best suits the framing bead ordered (quantity of lights as per our standards unless otherwise specified)</p>					





15-1200-E-00-03-830-111-F21

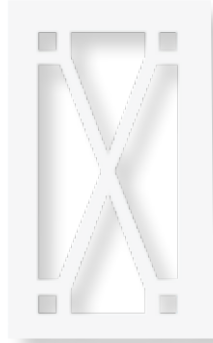

New

15-1200-E-00-03-833-F115



15-1200-I-00-03-821-F54



New

15-1200-E-00-03-822-F115



15-1200-M-00-02-815-F115

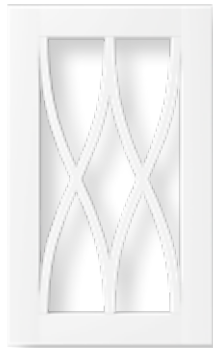

New

15-1200-ES-00-03-819-F131



15-4500-I-00-03-803-F54



New

15-1200-C-00-03-885-F21

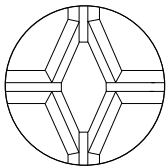

Mullions with lozenged accent.

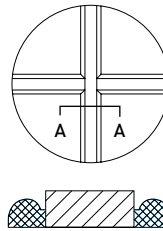

SECTION AA  
Mullions with added beads.





15-3300-M-00-02-915-F24



15-3300-M-00-02-805-F24



15-3200-P-00-02-805-915-F50



15-1202A-E-00-03-824-F115

New

RADIUS MULLIONS : Mainly used on quarter circle, half circle and vaulted open frames. Also available on other designs.



15-3100-ES-00-52-845-F131-P02



10-1202T-I-06-09-800-F45-P02



10-1202T-H-116-04-901-F01



15-1200-E-00-03-832-F21



10-1202T-R-98-03-400-837-F115

New



10-1202T-B-313-03-400-990-837-F21



Center panel # 91  
Closed wood lattice 2" x 2".



Center panel # 90  
Wicker + Birch backing



20-3102T-M-10-09-910-F115-P02

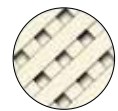

Open wood lattice  
1/2" x 1/2".



DESIGN BY 44N

**THIS DOOR COLLECTION** IS SPECIALLY DESIGNED TO ENHANCE ANY CUSTOMER DECOR. WITH THEIR IMPRESSIVE DETAILS, OUR DECO STYLE DOORS ADD DRAMATIC HEIGHT TO KITCHENS, BATHROOM VANITIES, CUPBOARDS, ENTERTAINMENT CENTERS, ARMOIRES, AND MORE.

WHETHER YOU GO FOR A COMBINATION OF DOOR/OPEN FRAME OR FOR A COMPLETE OPEN FRAME WITH MULLIONS, THEY ARE AVAILABLE IN CUSTOM SIZES AND A RANGE OF WOOD TYPES.

YOU CAN ALSO CHOOSE FROM THE FOLLOWING OPTIONS:

- FALSE OR TRUE LOUVERS
- OPEN OR CLOSED WOOD LATTICE
- ANY MULLION CONFIGURATION AS SHOWN IN PAGES 15-19
- PLYWOOD BACKING
- DRIFT WOOD / BARNWOOD OPTION

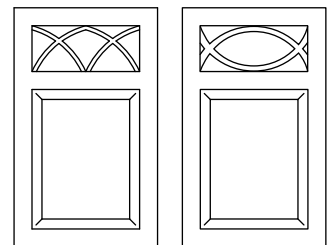

1202T 825

1202A 824

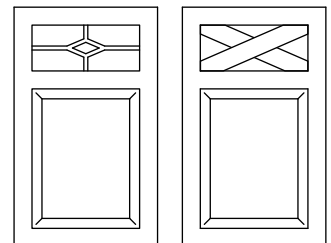

1202T 815H

1202A 837



- Door design : # 20-1200-E-10-03-109
- Drawer front design : # 30-6000-E
- Beaded inset frame : # 15-1200-E-00-04-252
- Vaulted appliqué : # 90-8100-E-10-03-250
- Beaded panelling : # 9825-E
- Turned wooden post 4" : # 90-6300-E
- Base moulding : # 9750-E-510
- Crown moulding : # 9800-E
- Wood type : Solid maple
- Color : # 131 Blanc design
- # 950 Brun automne (Island)



## APPLIED MOULDING

Add value to your projects with our applied moulding series. To be used on feature cabinets or the entire project.



20-1200-M-10-03-109-F131

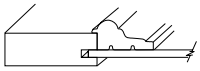

20-1200-M-20-03-170-F81

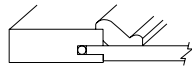

20-4500-M-10-03-620-230-F38

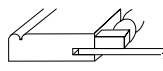

20-4500-E-10-03-641-236-F49-P02

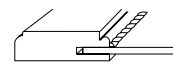

20-4500-I-10-03-620-105-F01

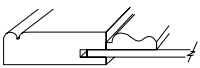

20-1200-I-10-03-250-F54

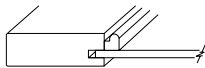

20-4500-I-10-03-150-F02

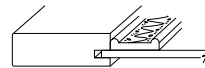

20-1200-M-10-03-160-F24

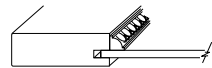

10-1200-ARN-313-03-110-F01

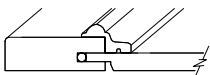

20-1200-ES-10-35-F131

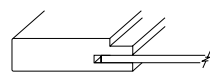

20-1200-P-10-03-155-F42

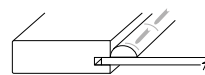

20-1200-AR-10-03-114-F81

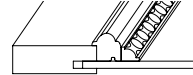

OR

20-1200-ES-10-03-259-F131

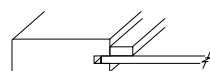



Door design : # 20-1200-I-10-03-[250](#)  
 Door / open frame design (C) : # 20-3102T-I-10-03-[250-915](#)  
 Door / open frame design (L, R) : # 20-3152T-I-10-03-[250-915](#)  
 Drawer front design : # 35-1200-I-10-03-[250](#)  
 Vaulted appliqué : # 90-8100-I-10-03-[250](#)  
 Crown moulding : # 9865-I  
 Wood type : Solid cherry  
 Qc White Oak (Island)  
 Color : # 134 Washington  
 # 21 Charbon





## ROUTERING

Most mullion designs shown in pages 16 to 19 of this Guide can be reproduced by grooving solid center panels. Again, they can be used as a focal point only (with basic doors beside) or on the entire project.



**New**

10-1200-M-93-03-111-F99

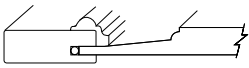

20-4500-I-20-21-270-F131

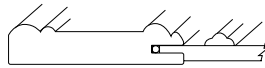



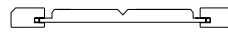



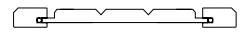













10-1200-I-312-03-316-F54-P24



10-3750-I-312-03-317-F54-P24



OPTION # On central panel	Width x Thickness
 105	1 1/16" x 5/16"
 109	1 1/2" x 3/4"
 110	1 5/16" x 3/4"
 111	15/16" x 3/4"
 114 *	1 5/16" x 3/4"
 150 *	1 1/4" x 3/8"
 155 *	3/4" x 5/16"
 160 *	1/2" x 3/8"
 170	1" x 9/16"

OPTION # On central panel	Width x Thickness
 205	3/4" x 5/16"
 220	1/2" x 3/16"
 210	3/4" x 5/16"
 230	1/2" x 3/16"
 236	1/4" x 3/16"
 238	1/4" x 1/4"
 250	3/8" x 3/8"
 257	3/4" x 5/16"
 259	3/8" x 3/16"
 260	3/8" x 3/8"
 270	3/4" x 5/16"



10-3300-E-312-09-313-F02-P02

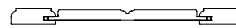

10-3300-E-312-09-312-F02-P02

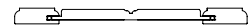

**New**

10-1200-CQ-302-03-310-F01-P24



N.B. : Available in most species  
(\* bass wood only)



# SIGNATURE STYLE

**PERSONALISATION AT ITS BEST** WITH THE SIGNATURE STYLE DOOR COLLECTION. AS PIONEERS IN APPLIED MOULDINGS, WE ARE PROUD TO INTRODUCE OUR NEWEST SELECTION. IT'S SURE TO DELIGHT YOUR MOST DISCRIMINATING CUSTOMERS AS THEY LOOK TO EXPRESS THEIR OWN UNIQUE STYLES.

DESIGNED TO ENHANCE YOUR PROJECTS, APPLIED MOULDINGS CAN GIVE BASIC DOORS A WHOLE NEW LOOK, ADDING WIDTH, DEPTH AND SUBSTANCE TO FRAMES. AND THAT'S NOT ALL! USING AN ECONOMICALLY PRICED DOOR, YOU CAN CREATE A VERY HIGH-END LOOK!

- AVAILABLE IN A NUMBER OF DESIGNS
- AVAILABLE IN MOST WOOD TYPES
- AVAILABLE WITH MOST OPEN FRAMES (WITH OR WITHOUT MULLIONS)
- OPTIMAL UTILIZATION OF NATURAL RESOURCES WHEN USED WITH FLAT PANEL AND / OR ECO SERIES COMPONENTS

20-1200-E-10-03 (2 5/8'')-[114](#)-F924  
20-1200-ES-10-03 (3'')-[259](#)-F131  
20-1200-I-20-03 (2 5/8'')-[170](#)-F905  
10-4500-E-93-03 (3 3/8'')-[751](#)-F77-P09





Door design :  
Drawer front design :  
Wood type :  
Color :

# 20-1200-T-410-89  
# 30-6000-T  
Solid teak  
# 01 Naturel



ROUTERING



OPTION / CENTER PANEL



10-4500-E-313-03-621-400-F02

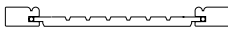

10-1200-AR-313-03-406-110-F911-P02

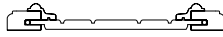

10-1200-E-313-03-405-F115

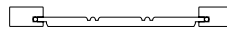

10-1200-ARN-313-03-250-400-F118  
99

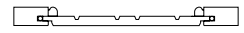

10-1200-IPE-313-03-403-993-F01

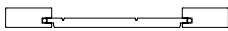

10-3200-M-312-09-315-F115-P02



10-1200-P-18-09-331-F02

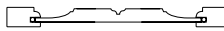

10-1200-C-05-52-302-F48

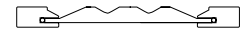

20-1200-E-444-89-F111



20-6500-CQ-448-03-F01

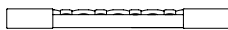

New



20-1200-T-410-89-000-F01



20-6500-T-405-87-F01





# TRADITION STYLE

**A NEW CLASSIC...** BEADED BOARD AND PLANK LOOK HAS IN FACT BEEN AROUND FOR DECADES. THIS NEW EXTENSIVE DOOR SELECTION GIVES YOU MORE POSSIBILITIES THAN EVER. EXPLORE THE FUTURE WITH THE PAST USING THIS TIMELESS AND COZY TRADITION STYLE.

WARM UP YOUR PROJECTS IN COMBINING THESE OPTIONS WITH THE WOOD TYPE OF YOUR CHOICE OR WITH PREMIUM MDF.

- AVAILABLE WITH MOST CENTER PANELS INCLUDING ECO SERIES...

### UP TO 13% SAVINGS

- AVAILABLE IN CUSTOM SIZES
- AVAILABLE IN VARIOUS CONFIGURATIONS (BEAD, HALF BEAD, WIDE AND SMALL «V» GROOVES)
- DISTANCE BETWEEN MACHINING AS PER YOUR SPECIFICATIONS OR RANDOM

10-1200-AR-313-03-<sup>99</sup>~~405-250~~-F131

10-1200-AR-313-03-<sup>10</sup>~~650-406-110~~-F911

10-1200-ARN-313-03-<sup>99</sup>~~250-400~~-F118

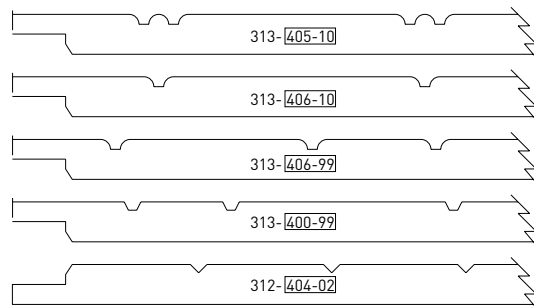



# ENVIRO STYLE

**NATURAL DESIGN INNOVATION** IS NOW AT YOUR FINGERTIPS WITH CARON'S NEW ENVIRO STYLE COLLECTION. INCLUDING STURDY CENTER PANELS CONSTRUCTED ENTIRELY FROM RECLAIMED AGRICULTURAL FIBER, THIS DURABLE PRODUCT IS AN ENVIRONMENTALLY FRIENDLY COMPLEMENT FOR WOOD.

TAKE ADVANTAGE OF THIS NEW ELEMENT OF BEAUTY TO MODERN INTERIOR DESIGN. APPLICATIONS ARE NUMEROUS AS PER BATHROOM AND KITCHEN CABINETS, FURNITURE, ENTERTAINMENT CENTERS ETC. CENTRAL PANELS ARE AVAILABLE IN TWO THICKNESSES: 3/8" (9.5MM) AND 3/4" (19MM), YOU CAN PERSONALIZE YOUR PROJECT WITH A FRAME IN THE WOOD TYPE OF YOUR CHOICE (SHOWN HERE WITH SOLID TEAK).

- INNOVATIVE DESIGN + CLEAN LINES
- STURDY, STABLE AND CONSTRUCTED ACCORDING TO OUR QUALITY MANAGEMENT SYSTEM REGISTERED UNDER ISO 9001
- EASY TO FINISH WITH WATER, OIL, URETHANE BASED PAINT, LACQUER OR STAIN
- REDUCES FOREST CLEAR CUTTING AND AIR POLLUTION

A - 20-1200-T-410-89-F01

B - 20-1200-T-405-87-F01

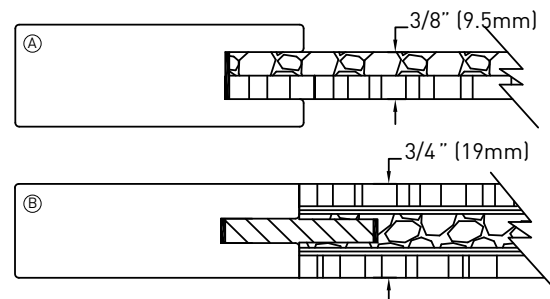

# TROPICAL STYLE

**BRING A TOUCH OF EXOTICISM, FRESHNESS, AND LAID-BACK GOOD LOOKS TO YOUR HOME. MADE FROM COCONUT, OUR TROPICAL STYLE COLLECTION AND ITS LUMINOUS, WARM TONES AND SOPHISTICATED TEXTURES ADD A VACATION-LIKE FEEL TO YOUR HOME.**

AVAILABLE WITH EITHER CONTEMPORARY (VERSA) OR CLASSIC (SHAKER FRAME) STYLING, THESE DOORS FEATURE 3D DESIGN AND ALL THE NATURAL AND AUTHENTIC BEAUTY OF WOOD COUPLED WITH COCONUT. OUR EXCLUSIVE, INNOVATIVE TROPICAL STYLE COLLECTION IS DOUBLY AS ENVIRONMENTALLY FRIENDLY AND RESPECTFUL OF THE ENVIRONMENT BECAUSE IT OPTIMIZES WOOD USE BY RECYCLING COCONUTS.

- CHOOSE FROM A SELECTION OF THREE (3) GENUINE COCONUT CENTER PANELS
- AVAILABLE IN MOST WOOD TYPES
- AVAILABLE IN CUSTOM SIZES
- DELIVERED TO YOU FINISH SANDED OR PREFINISHED IN ATTRACTIVE COLORS

20-6500-CQ-448-03-F01  
20-1200-M (GR7)- 443-89-F01  
20-6500-E- 447-03-F221

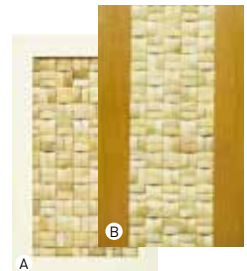

A - 20-1200-E-444-89-F111  
B - 20-6500-CQ-447-03-F01



Door design : # 20-1200-E-10-01 (3 3/8" - 2 7/8")- 700 -P04  
Drawer front design : # 30-6000-E-00-P17  
Light valance : # 9750-E-P08  
Crown moulding : # 9840-E  
Wood type : Solid maple  
Color : # 129 Blanc / Glaze

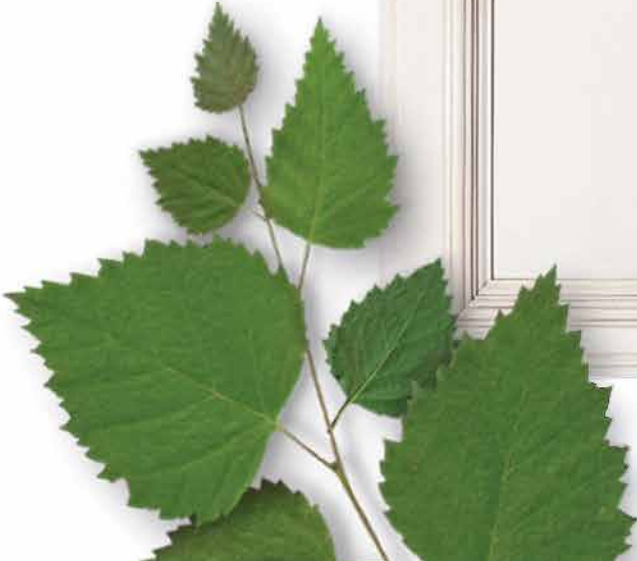

## APPLIED MOULDING / ROUTERING

These options are also available with the solid raised center panel of your choice.



10-1200-E-06-01-700-F24-P04

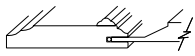

Please specify 3 3/8" stiles,  
2 7/8" rails.



10-1200-M-313-52-760-F38

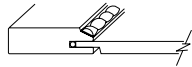

Rope accent.



20-1200-C-10-52-765-F01



Wood inlay. One accent type only.  
Suitable on most wood types.



20-4500-E-10-03-650-F115

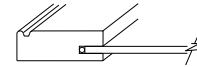

On mitered components  
and 90° assembly.



20-1200-I-10-03-585-F01

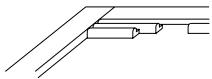

20-4500-E-10-17-000-F115

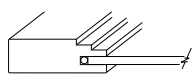

Mitered components only.



20-1200-F-10-03-500-F02

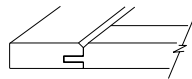

«V» joint  
on mitered components  
and 90° assembly.



20-1200-T-10-03-590-F01

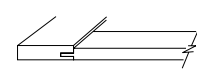

5/8" thick rails.



10-1200-E-02-01-510-F131



On mitered components  
and 90° assembly.



20-1202B-E-10-03-973-F02

- 1- Single flushed peg.  
Option # 970
- 2- Double flushed pegs.  
Option # 971

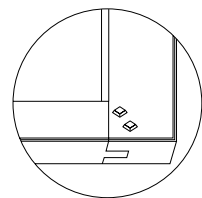

- 3- Single raised peg.  
Option # 972
- 4- Double raised pegs.  
Option # 973



10-4500-E-93-03-751-F77



**New**



# ARCO STYLE

**YOU PREFER CURVED LINES...** THIS COLLECTION OFFERS ONE-OF-A-KIND STYLE AND FLEXIBILITY TO USHER IN A NEW ERA IN HOME DESIGN. UNLEASH YOUR IMAGINATION.

THE ARCOSTYLE COLLECTION CAN BE USED FOR ALL OR PART OF A PROJECT AND IS READILY AVAILABLE IN CUSTOM SIZES. YOU CAN ALSO CHOOSE FROM...

- APPLIED MOULDINGS IN AN ARRAY OF STYLES (ROPE, CLOVER, BEADED, ETC.)
- MOST WOOD TYPES
- FLEXIBLE CONFIGURATIONS (ARCHED, VAULTED, QUARTER CIRCLE, HALF CIRCLE, GOTHIC, ETC.)

- 10-3100-E-311-03(3")-F131
- 10-3100-E-301-03(3")-753-F38-P02
- 20-3100-I-10-01(3")-700-F01-P02
- 90-8140-I-04-45-F54

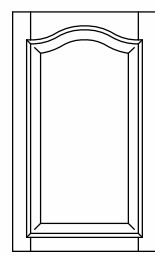

1300

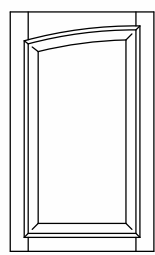

3150

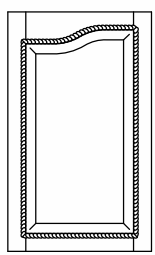

3400

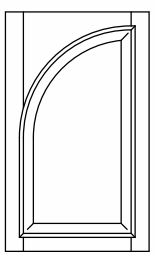

3300

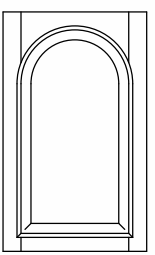

3200

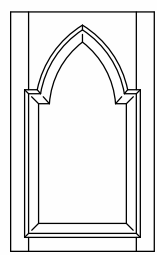

3700

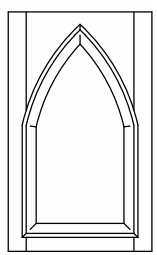

3750





Appliance door design : # 10-1202-ES-321-32  
Door design : # 10-1200-ES-321-32  
Drawer front design : # 35-1200-ES-321-32  
Open frames : # 15-1200-ES-00-32-830  
Island top : # 90-4060-N-(Walnut)  
Wood type : Silver maple  
Color : # 131 Blanc design



Most door designs can be produced in multi panel and / or wainscoting version. This, in various configurations, either with raised or flat center panels. This page contains only a few possibilities... create your own by indicating stile + rail widths and position (if not equal panels) along with outside measurements.

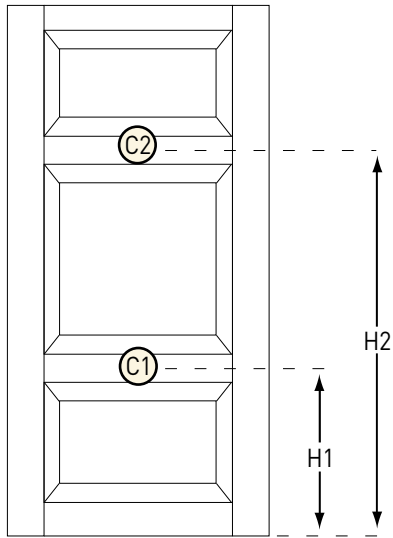

10-1203 A

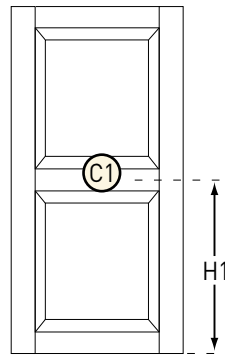

10-1202 A

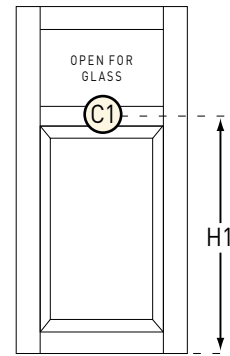

10-1202 T

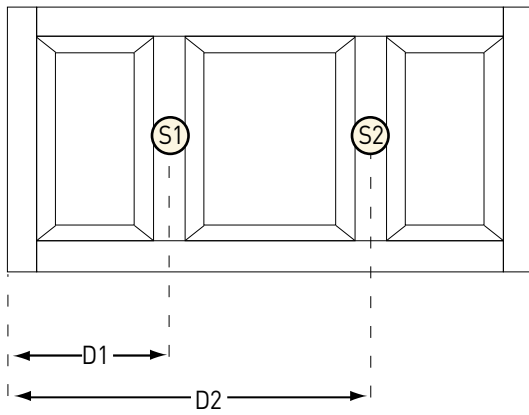

10-1203 B

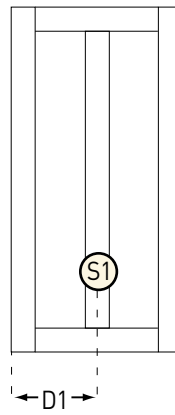

20-1202 B

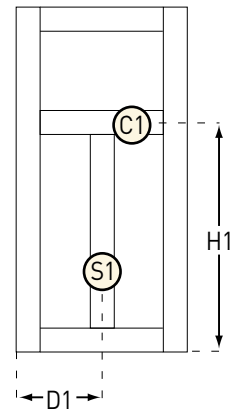

20-1203 D

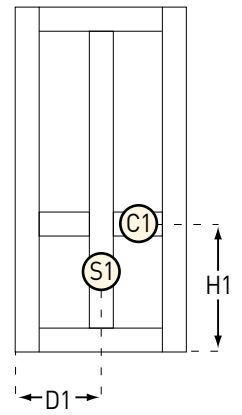

20-1204 C

**LEGEND :**

- C1 : Crosspiece #1 (from bottom)
- C2 : Crosspiece #2 (from bottom)
- S1 : Stile #1 (from left)
- S2 : Stile #2 (from left)

- H1 : Height from bottom to centre of crosspiece #1
- H2 : Height from bottom to centre of crosspiece #2
- D1 : Distance from left to centre of stile #1
- D2 : Distance from left to centre of stile #2



Door design : # 10-4500-M-04-45  
Drawer front design : # 30-4500-M-14-45  
Crown moulding : # 9860-M  
Ornamental applique : # B51  
Beaded panelling : # 9825-M  
Turned wooden post 2" : # 90-6300-M  
Wood type : Solid birch  
Color : # 213 Katadine



As multi panel doors, these components are available in most designs, with various configurations using raised, recessed or M.D.F. panels. Applications are numerous such as wall panelling, staircases, islands, office furniture to name a few. Make sure to indicate stile + crosspiece widths and position (if not equal panels) along with outside measurements.

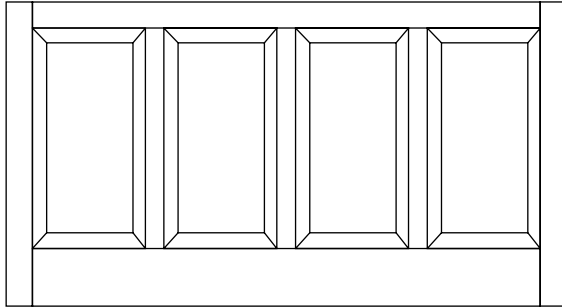

10-1204 B

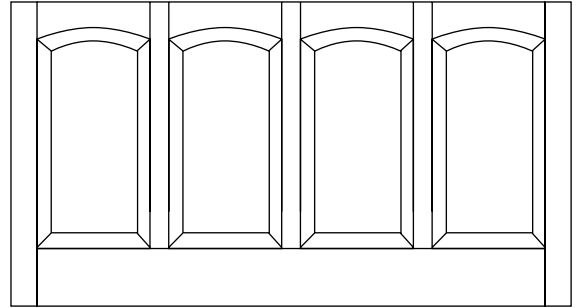

10-3104 F

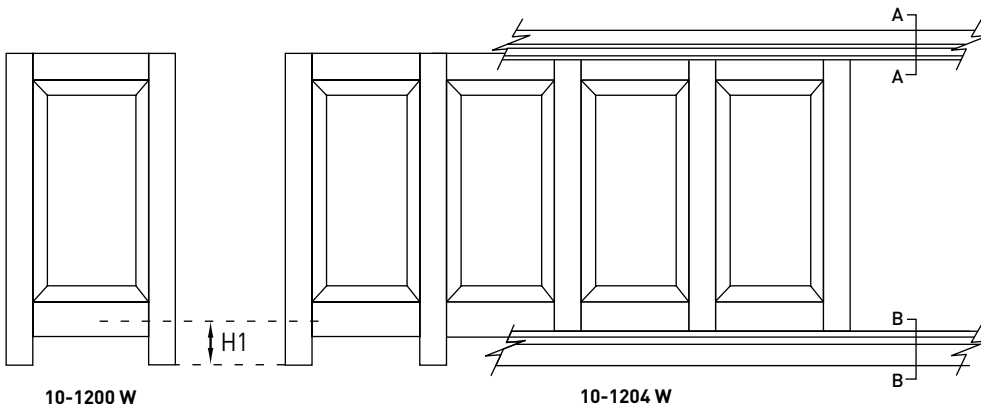

10-1200 W

10-1204 W

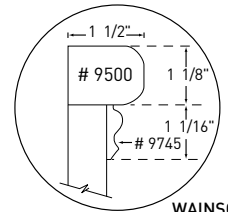

WAINSCOT CAP MOULDINGS SECTION AA

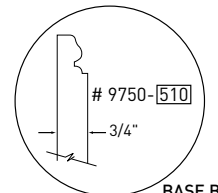

BASE BOARD SECTION BB

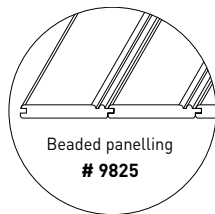

Beaded panelling # 9825



Also available: Barn panelling # 9822-997

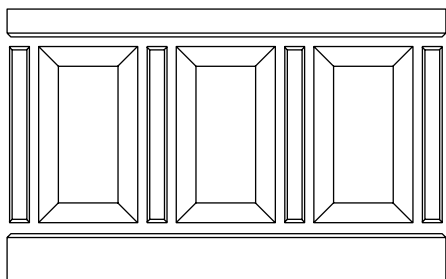

10-1203 B (unassembled)

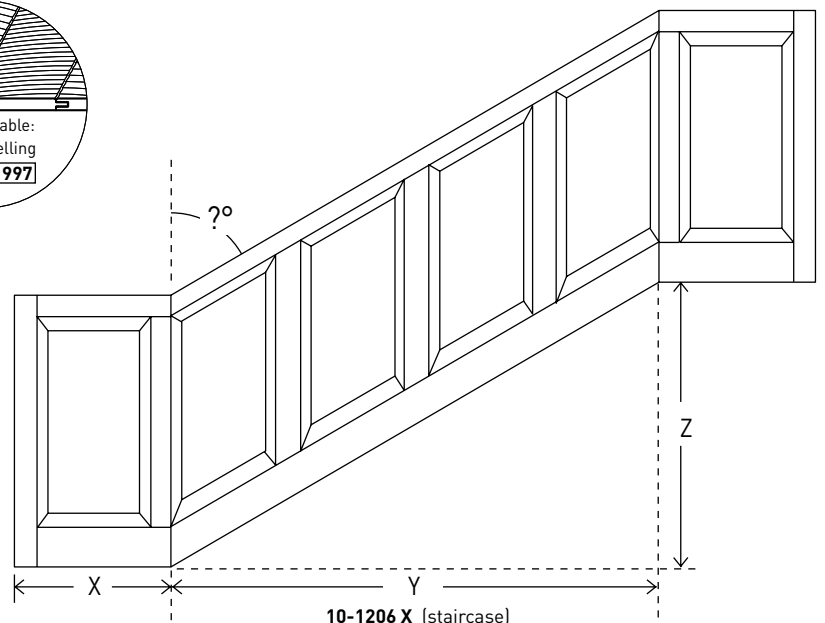

10-1206 X (staircase)



Door design : # 10-1200-E-321-01  
Drawer front design : # 30-1200-E-321-01  
Ogee : # 9541  
Wood type : Solid maple  
Color : # 131 Blanc design

# COLORS 3.0

CARON COLOR SELECTION A WIDE RANGE OF ATTRACTIVE COLORS AND TEXTURES

**FREE**  
OR **50% OFF\***



**GOT A BOTTLENECK WITH FINISHING?**

**WE GOT YOUR BACK WITH OUR COMPLETE FINISHING PROGRAM!**

MORE THAN EVER LACQUERED COLORS AND OPAQUE FINISHES ARE IN BUT INVOLVE MANY STEPS. CARON CAN ASSIST YOU IN MEETING THOSE CRITICAL DEADLINES.

WHETHER PRIMER COATS ONLY OR COMPLETE PREFINISHED, ON MDF OR ON WOOD COMPONENTS WE HAVE IT ALL. QUALITY INCLUDED!

ASK FOR YOUR FREE\* PROFESSIONAL COLOR SELECTOR (63 ACTUAL WOOD/MDF SAMPLES IN A PRACTICAL ARCHITECT FOLDER) WITH YOUR NEXT ORDER OR AT 50% OFF LISTED PRICES, SHIPPING + HANDLING INCLUDED\* .



- A: Natural (clear coat)
- B: Light stain
- C: Premium stain (shading)
- D: Opaque
- E: Glaze
- F: Light glaze (brushed)
- G: Worm holes, rubbed corners
- H: Base coat only **New**

**FINISHING**

As our numerous door designs, CARON'S exclusive color selection along with special treatments gives you unlimited possibilities to satisfy all your customer's dreams. In fact, most of our basic colors can be dressed up with any of our four (4) glaze accents (Glacis white, golden, dark brown and coffee), not to mention our distressed treatments such as rubbed corners worm holes and textured options Drift wood or Barn wood. N.B. For pages 38, 39 and 40 wood type: maple (unless otherwise specified). The finished appearance will varie for a same # according to the wood types.

Naturel	F01 A	F21 C	Charbon
Naturel ombré	F02 B	F41 DE	Glacis vieillot
Apricot	F03 C	F48 C	Haut contraste
Brun foncé	F04 C	F54 C	Stradivarius on Cherry
Céruse	F05 C	F58 E	Glacis automne
Céruse on quartercut white oak	F05-990 C	F77 C	Amande grillée
Chêne pâle on Oak	F09 B	F81 C	Terra rosa
Châtaigne	F14 C	F98 D	Prune noire
Moka java	F15 C	F100 D	
Nevada	F18 C	F108-990 C+	Moka on quartercut white oak
Noyer	F20 C	F111 DE	Crème glacis brun

All products used in finishing are of the highest quality, high in solids and low v.o.c. Water and polyurethane based finishes are also available. Ask for Caron's color selection to see our range of finishes (Ref. Pages 38 and 77). Also available touch-up kits and finishing products in 1 or 4 litre format.

DRILLING FOR HINGES

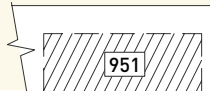

N.B. Drilling for hinges : option #951

Crème brûlée	F117 D	F171 D	Rubis
Matin d'automne	F118 E	F172 D	Canari
Espresso	F124 C	F173 D	Lime
Porto	F125 C	F175 D	Cape Cod
Acajou vieillot	F127 C	F179 DE	Algue on MDF
Blé d'automne	F128 C	F180 D	Inox on MDF
Blanc / Glacis	F129 DE	F188 C	Mustang
Rouge cordova	F130 C	F203 D	Atlantide
Blanc design	F131 D	F207 D	Dentelle
Ardoise	F169 C	F217 D	Menhir
Ardoise on quartercut white oak	F169-990+ D+	F221 D	Pôle sud

## DID YOU KNOW?

To make your life simpler, you can choose from among our premium quality base coats.



### OUR PRIMERS

F650



F651

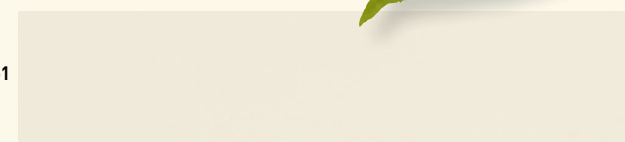

F652

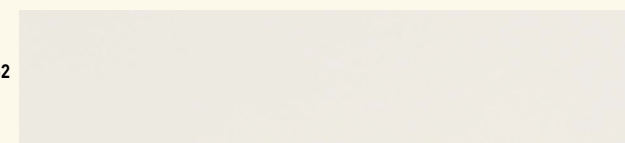

F653

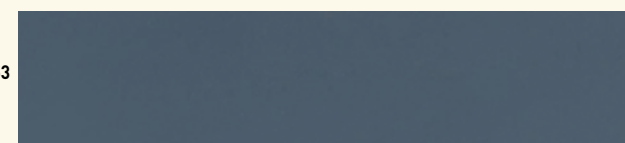

F654

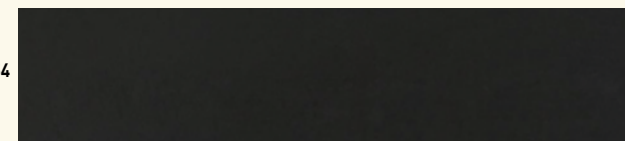

F655

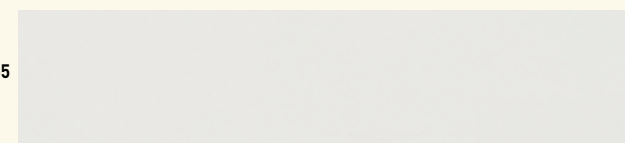

F657

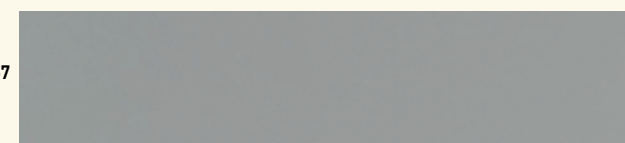

F658

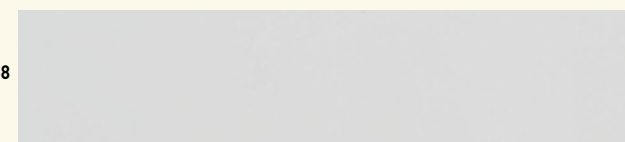

F659

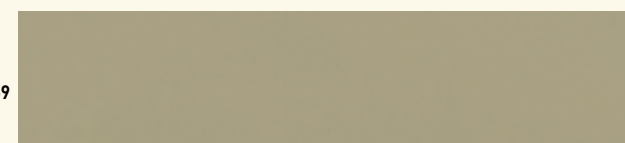











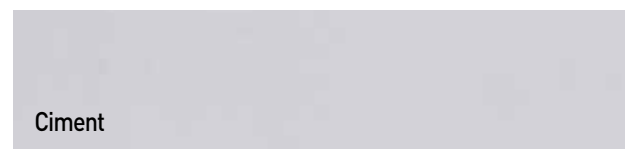





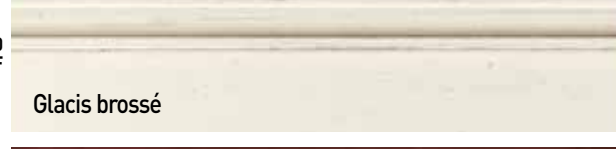



## THE PERFECT PALETTE

Save time and money with our prefinished doors. We offer over 100 tints and colors, many matched to the Benjamin Moore paint collections. Here's a peek at our wide selection of on-trend yet timeless colors. For even more inspiration, go to [caronindustries.com/en/finishing](http://caronindustries.com/en/finishing).

	F239 D
	F249 D
	F252 D
	F260 D
	F267 A
	F272 A
	F277-990 A
	F283 A
	F287 A
	F289 A
	F751 A

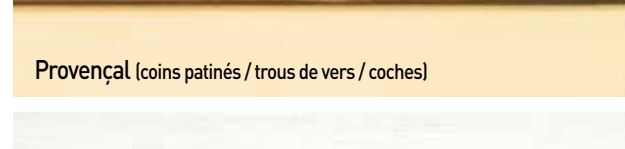
## FINISHING

Aging may alter these finishes. Take this into consideration for comparison with former samples and / or projects. These samples are a general representation of the wood types & colors. Since nature never duplicates itself, you may notice a slight difference in color from one order to another, between components, even within the same component. We suggest to order a sample door to see actual colors prior to ordering complete projects.

	F193 D	F532 HTX DE	
	F181 D	F533 HTX DE	
	F182 D+	F542 HTX D	
	F341 C	F750 F	
	F406 E	F902 C	
	F444 D	F905 C	
	F449 C	F913 C	
	F492 TX DE	F922 C	
	F494 TX C	F923 C	
	F502 DE	F924 C	
	F530 HTX DE	F950 C	





Door design : # 20-1200-E-20-03  
Open frame design : # 15-1200-E-00-03-840  
Drawer front design : # 35-1200-E-20-03  
Crown moulding : # 9542-E  
Valance : # 9750-E-P16  
Wood type : Solid maple  
Color : # F124 Espresso  
# F129 (Island) Blanc / Glaze



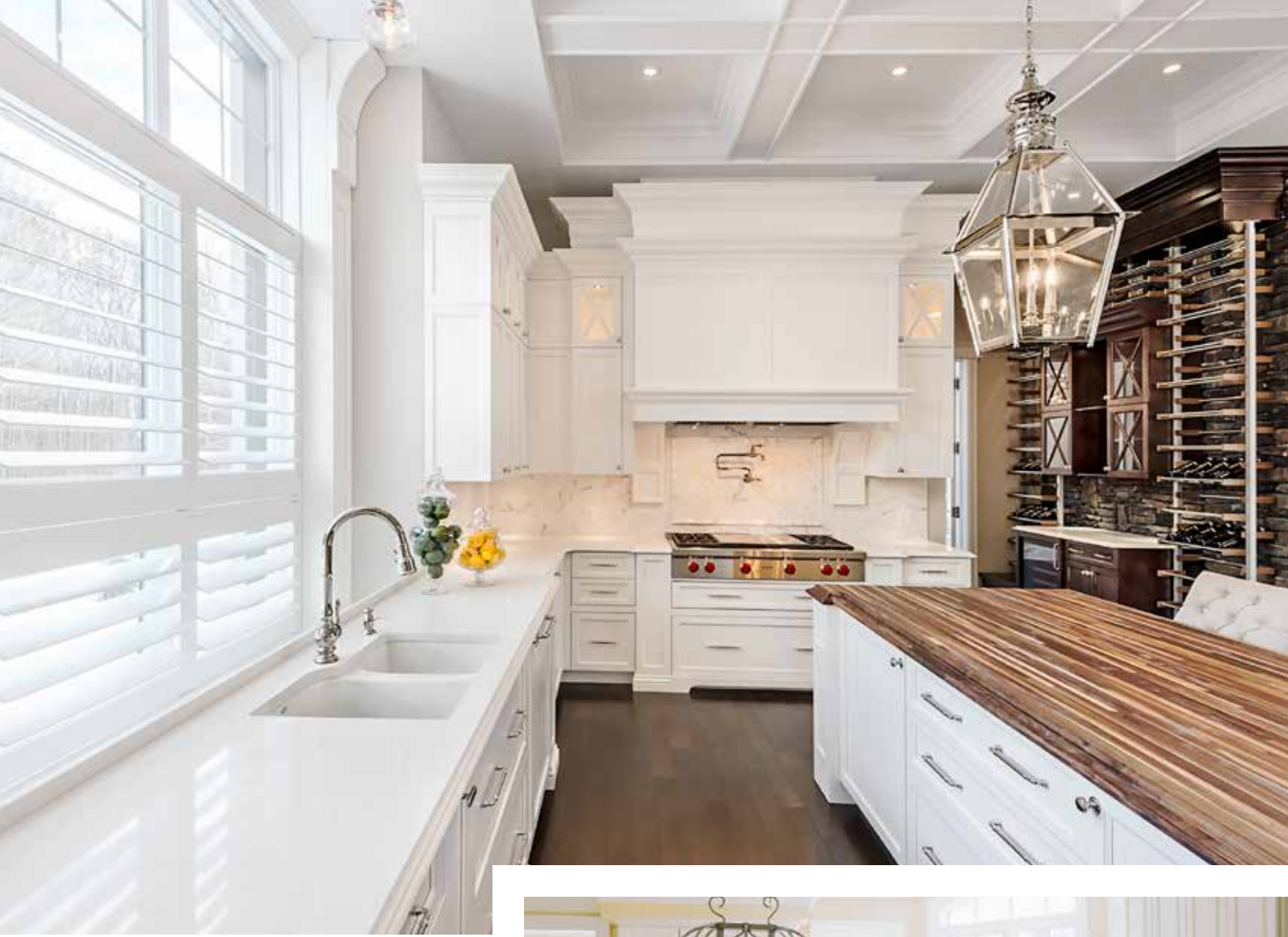

Door design : # 10-1200-ES-321-32  
 Drawer front design : # 30-1200-ES-321-32  
 Open frames : # 15-1200-ES-00-32-830  
 Island top : # 90-4060-N-(Walnut)  
 Wood type : Silver maple  
 Color : # 131 Blanc design



Door design : # 70-1200-041-P02  
 Drawer front design : # 72-1200-041-P02  
 Crown moulding : # 9865-E  
 Beaded panelling : # 9825-E  
 Fluted pilaster : # 90-6250-E-004  
 Wood type : Fibreboard (M.D.F.)  
 Color : # 115 Blanc



# MDF STYLE

**CLEAN, CLASSY LINES, THE MDF STYLE COLLECTION OF CABINET AND FURNITURE DOORS TRANSCEND CURRENT STYLES AND TRENDS. LACQUERED COLORS AND OPAQUE FINISHES ARE ALWAYS IN. WITH THE MDF EVENT, IT'S EASIER THAN EVER TO GET YOUR HANDS ON THIS TRUE CLASSIC. QUALITY AND FAST SERVICE, SIGNED CARON.**

STARTING FROM 3.58\$\* NET/SQ. FOOT, THE MDF STYLE COLLECTION IS WELL SUITED FOR ALL DECORS AND BUDGETS. CHOOSE WELL SANDED UNFINISHED COMPONENTS (A) OR SAVE TIME AND MONEY BY SELECTING TOP QUALITY PRIMER COATS ONLY (B) OR PREFINISHED (C) IN A RANGE OF ATTRACTIVE COLOURS. FINISHING SERVICES AVAILABLE FROM 4.76\$\*NET/SQ. FOOT.

- CHOOSE FROM 5 THICKNESSES; 11/16", 3/4", 13/16", 7/8", 1 1/16"
- OPTIMAL PRICE-QUALITY RATIO, FROM THE BEST MDF BOARD AVAILABLE IN THE MARKET TODAY (ALSO AVAILABLE FORMALDEHYDE FREE)
- HIGH-END PROJECTS AT LITTLE COST
- SINGLE PIECE CONSTRUCTION (1) WITH OR WITHOUT MELAMINE BACKING
- TWO PIECE CONSTRUCTION, NO ASSEMBLY JOINTS (2)
- FIVE PIECE CONSTRUCTION, 90° OR 45° ASSEMBLY (5)
- SANDING USING THE LATEST TECHNOLOGY
- FREE DELIVERY WITH 20 DOORS OR MORE\*.

\*Conditions may apply.



70-1200-R-03-F131

70-4000-F131

75-1200-R-47-165-F287

20-4500-R-47-45-F193

75-1202T-R-47-167-400-837

20-4500-R-47-21-F750

# ONE PIECE PREMIUM MDF DOORS (SQUARE CORNERS)

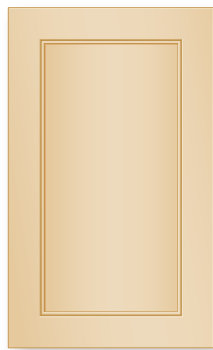

70-1200-010

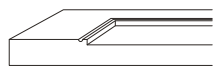

70-1200-032

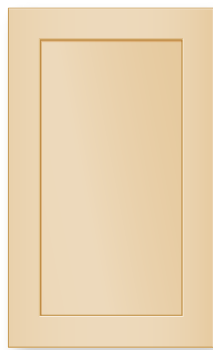
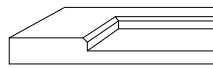

70-1200-033

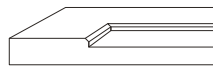

70-4000

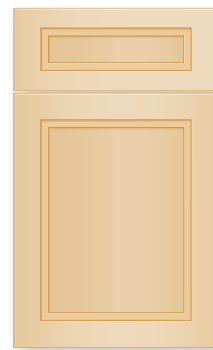
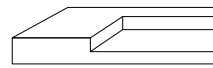

70-4050-007

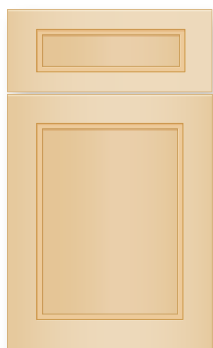
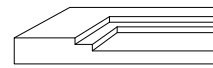

70-4050-008

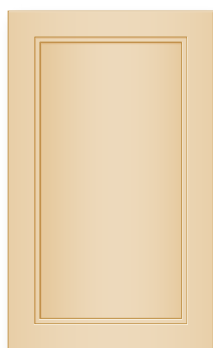
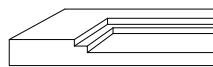

70-4050-009

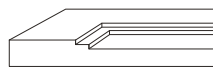

70-4050-209

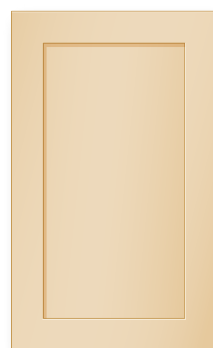
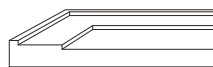

70-4100

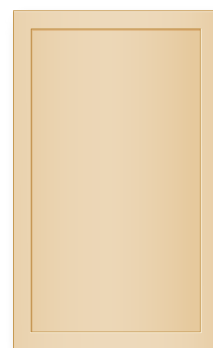
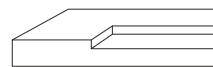

70-4120

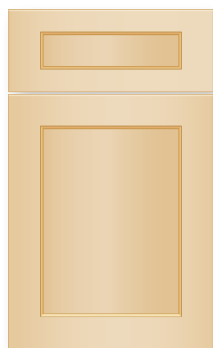
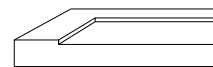

70-1200-030

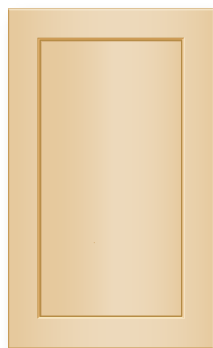
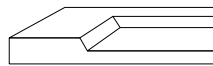

70-1200-031

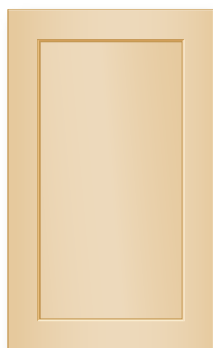
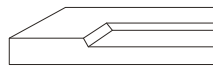

70-1200-034

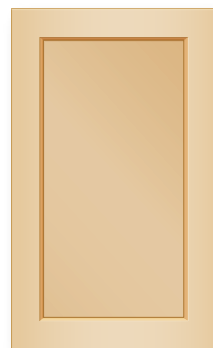
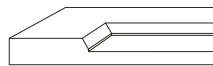

70-1200-036

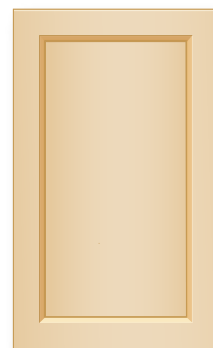
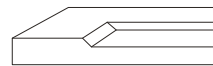

70-1200-040

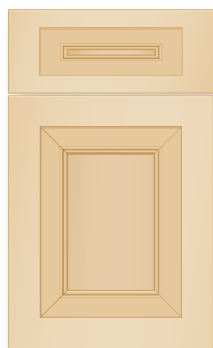
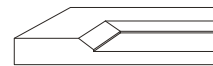

70-1200-044

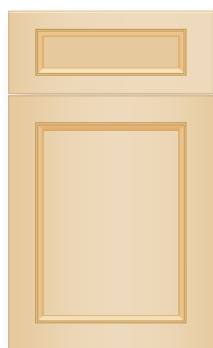
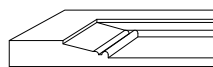

70-1200-045

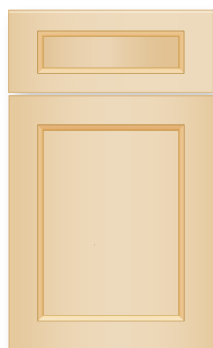
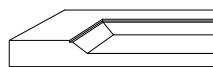

70-1200-046

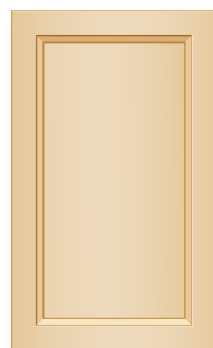
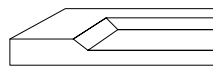

70-1200-052

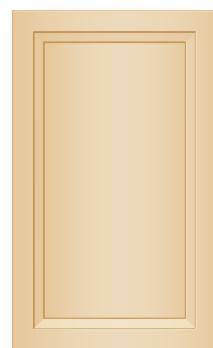
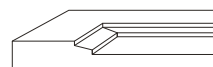

70-1200-053

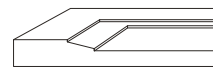

N.B.: Pages 44-45. For the complete selection of center panels, interior mouldings and exterior profiles, please refer to pages 10, 11 and look for this symbol \*.  
 \*For mullions most options shown on pages 15 to 19 are available. Options shown on pages 20 to 32 are also available in MDF. Please also refer to page 80 for our complete selection of designs.



**ONE PIECE PREMIUM MDF DOORS (SQUARE CORNERS)**

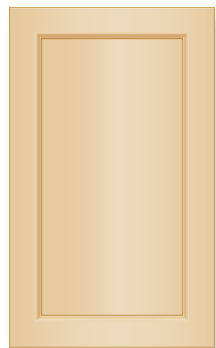

70-1200-038

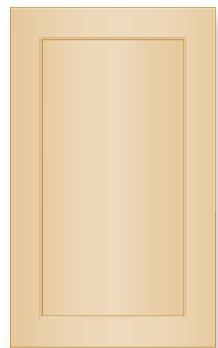
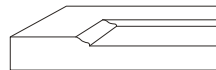

70-1200-039

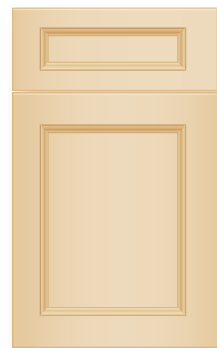
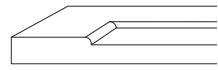

70-1200-048

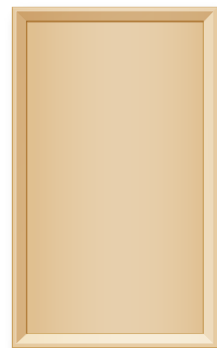
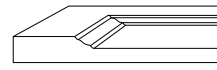

70-1200-253

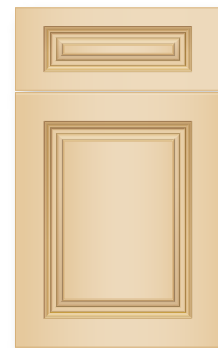
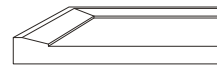

70-1200-003

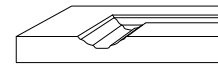

70-1200-004

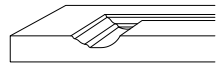

70-1200-014-P02

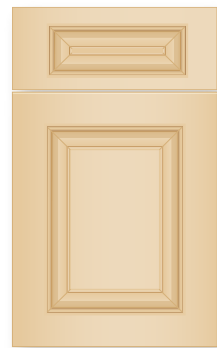
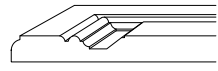

70-1200-019

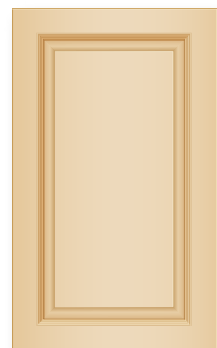
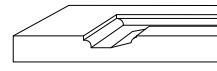

70-1200-021

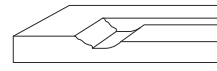

70-1200-041-P72

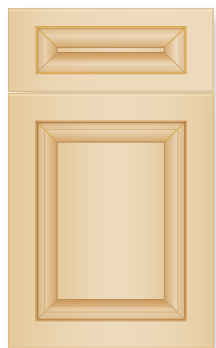
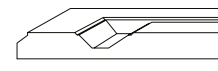

70-1200-051

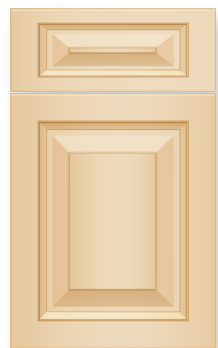
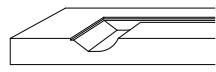

70-1200-061

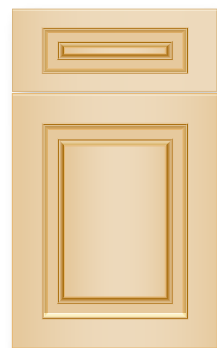
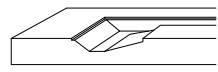

70-1200-071

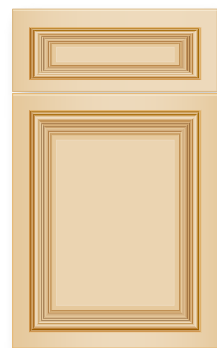
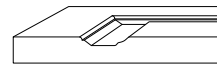

70-1200-081

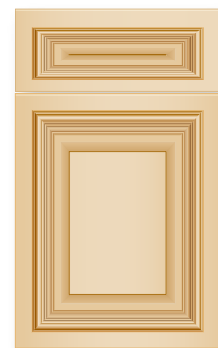
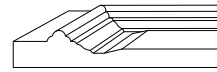

70-1200-086

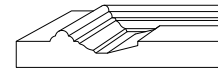

**TWO PIECE PREMIUM MDF DOORS (SQUARE CORNERS)**

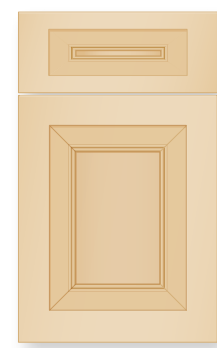

75-1200-47-165

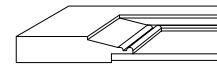

75-1200-47-167 (3/8")

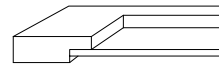

75-1200-47-168 (1/4")

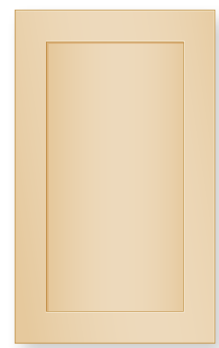
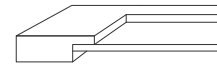

75-1200-124-154 (1/8")

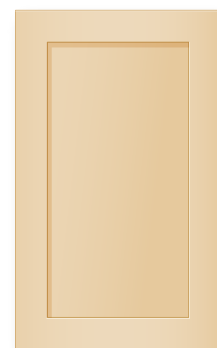
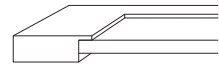

75-1200-47-178 (1/4")

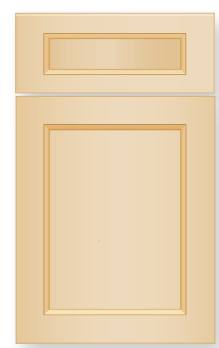
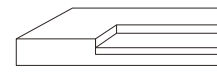

75-1200-124-170

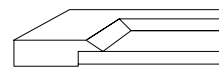

## FIVE PIECE PREMIUM MDF DOORS (SQUARE CORNERS)

45° ASSEMBLY / Sturdy micro finger joints construction

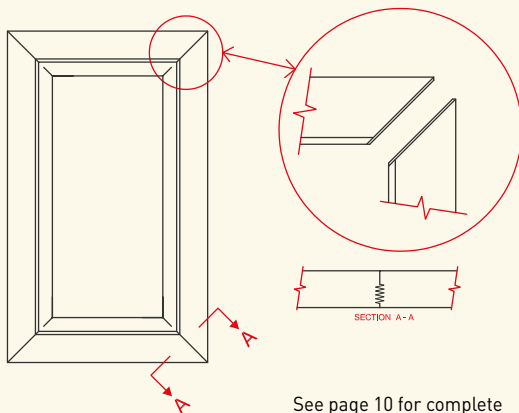

10-4500-R-95-09

See page 10 for complete selection of mouldings.

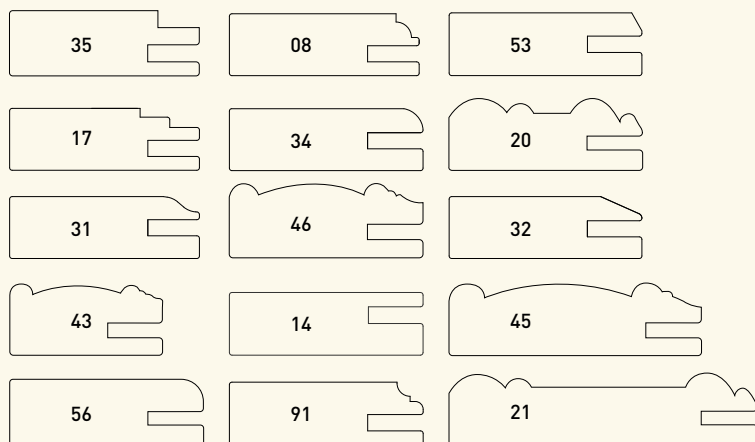

LAMINATED MDF

90° ASSEMBLY / Mortaise + Tenon and 45° ASSEMBLY

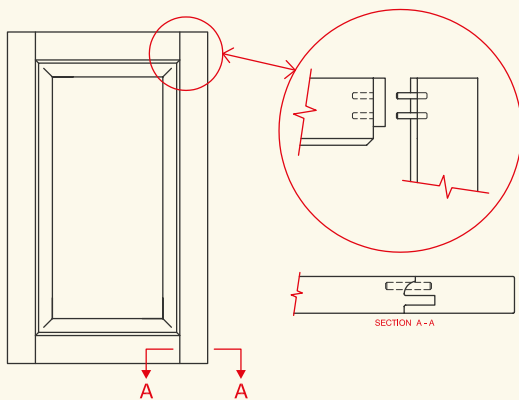

10-1200-R-95-09-917

Dowels are optional

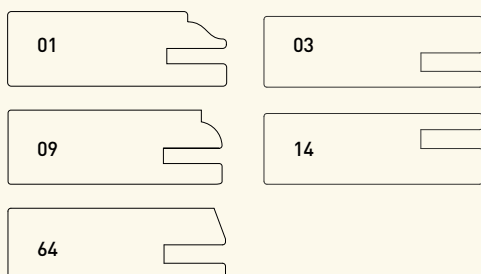

# EUROLAM

**OPEN THE DOOR TO A WORLD OF STYLE, FLEXIBILITY AND ACCESSIBILITY** EUROPEAN-INSPIRED EUROLAM MDF LAMINATED DOORS LEND THEMSELVES TO A WIDE RANGE OF DECORS: KITCHEN, BATHROOM, CLOSETS AND MORE. THEY COME IN LOTS OF DIFFERENT STYLES, COLOURS AND TEXTURES FOR ALL YOUR DESIGN NEEDS. WITH QUALITY PRODUCTS AT VERY AFFORDABLE PRICES, YOU CAN OPEN THE DOOR TO A WORLD OF RENOVATIONS!



**PROMOTIONAL SUPPORT**  
(SEE PAGE 77).



- A - 88-8000-F492
- B - 88-8500-F494
- C - 88-8950-F494
- D - 88-8300-F542
- E - 88-8900-F492

**ACCESSORIES**

ESSEX



85-1200-5793-F530

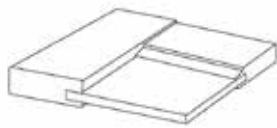

SUSSEX



86-1200-5793-F530

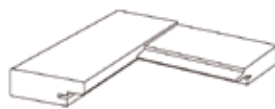

85-1200-5741-F533



VELLINGE



85-6500-4793-F444



TRENTINO



85-4500-4795-F533

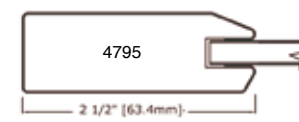

UMBRIA



85-4500-5995-F532

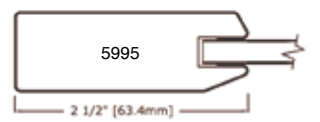

PROVENCE



85-4500-4300-F494



RHÔNE



85-4500-4346-F492

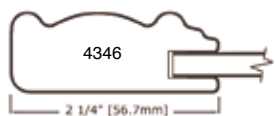

SKAGËN



85-4500-4793-F542



SMÖGEN



85-4500-5993-F532



OXFORD



85-4500-4741-F532



85-4500-4793-844-400-F533



N.B. Group #85: Doors. Group #86: Open frames. Group #87: Drawer fronts.

F-530 HTX\*\*

F-532 HTX\*\*

F-533 HTX\*\*

F-542 HTX\*\*

F-100

F-444

F-449\*

F-492 TX\*

F-494 TX\*

ALL OTHERS  
COLOURS / TEXTURES



PROVENCE / RHÔNE

HTX : High texture. TX : Textured.  
\*Available for models Provence and Rhône only.  
\*\*Not available for models Provence and Rhône.

CALABRIA  
86-4500-4723-F255

Contrasting  
stainless colour  
open frame/door

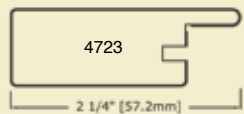

Door design : # 88-6600-50-F960  
Drawer front design : # 88-6600-50-F960  
Color : # Glacier  
Sheen : # 95°  
Laminated wood Top : # 90-4060-T-F780





# BRILLIANT STYLE

**STREAMLINE, CLEAN, CLASSY, SIMPLY BRILLIANT** CARON'S BRILLIANT COLLECTION OF HIGH GLOSS CABINET AND FURNITURE DOORS, REFLECT THE TASTE FOR HIGH END CONTEMPORARY PROJECTS. RESOLUTELY EUROPEAN, RESOLUTELY AFFORDABLE.

MADE FROM AN ECOLOGICAL MULTI LAYERED MDF EUROPEAN BOARD, THE BRILLIANT COLLECTION PROVIDES YOU WITH A MIRROR LIKE REFLECTION, THE HIGHEST GLOSS LEVEL IN THE INDUSTRY. YOU CAN PERSONALIZE THESE DOORS; CHOOSE A MATCHING EDGE, BRUSHED ALUMINIUM OR A TWO TONED BRUSHED ALUMINIUM/COLOR\*. IDEAL FOR KITCHEN CABINETS, BATHROOMS, WALK IN CLOSETS, ENTERTAINMENT CENTERS, COMMERCIAL APPLICATIONS, ETC.

- FAST TURN AROUND TIME, PRODUCT READY TO USE
- AVAILABLE IN FOUR COLORS: CHARCOAL, BARN, GLACIER, FERRARI
- HIGHEST SCRATCH AND HEAT RESISTANCE ON THE MARKET
- 100% PVC FREE PANEL
- DEPTH EFFECT AND EXTRA SMOOTH SURFACE
- EASY TO CLEAN AND MAINTAIN
- FREE DELIVERY FOR 20 DOORS OR MORE\*

\*Conditions may apply.



88-6600-59-F965

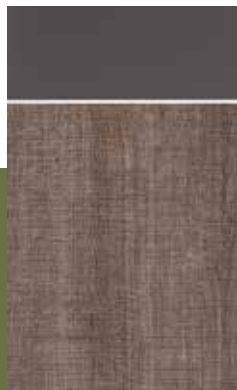

88-6600-50-F975



88-6600-50-F975



88-6600-55-F980



88-6600-50-F960



88-6600-50-F960



# EUROSTYLE

**PRESENTING AN ALTERNATIVE TO SOLID WOOD DOORS**—THE EURO STYLE LAMINATED WOOD COLLECTION. MODERN, SLEEK, PURE LINES WITH OPTIMAL USE OF NATURAL RESOURCES. THEY'RE SURE TO PLEASE WOOD LOVERS.

YOUR CUSTOMERS WANT A MODERN CLEAN LOOK WITHOUT COMPROMISING THE LIFE AND NATURAL WARMTH OF AN EXQUISITE WOOD GRAIN. OUR NEW EURO STYLE COULD DO JUST THAT AND MUCH MORE...

- TOP QUALITY WOOD SKIN ON MDF CORE (HORIZONTAL OR VERTICAL GRAIN)
- WIDE SELECTION OF DOMESTIC AND EXOTIC SPECIES (FLAT CUT RED OAK, BIRCH, MAPLE, CHERRY, MAHOGANY, WALNUT AS WELL AS QUARTER CUT ZEBRAWOOD, WENGE, BAMBOO)
- OPTIMAL USE OF NATURAL RESOURCES
- EUROPEAN FLAIR
- STURDY, STABLE AND EASY TO CLEAN

90-6400-A-00-00--F85

90-6400-I-00-00--F902

90-6400-Z-00-00--F01

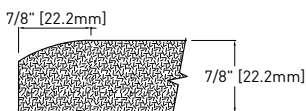



# EURO<sup>+</sup>STYLE

**HERE IS THE LATEST TAKE ON EURO STYLE SERIES. THE NEW EURO+ LAMINATED WOOD DOOR COLLECTION FEATURES SLEEK DESIGN, RICH FINISHES AND MORE SOLID WOOD FOR INCREASED DURABILITY.**

JUST LIKE THE ORIGINAL COLLECTION, EURO+ STYLE GIVES YOUR CUSTOMERS THE MODERN CLEAN LOOK THEY WANT WITHOUT COMPROMISING THE LIFE AND NATURAL WARMTH OF FINE WOOD. THE POPULAR SOLID WOOD NARROW FRAME IS AVAILABLE UP TO 7/8" WIDE. (CAN ALSO BE MADE OUT OF BRUSHED ALUMINUM 'T' MOULDING (REF. Ⓐ FOLLOWING PAGE).

- STURDY MITERED CONSTRUCTION
- WIDE SELECTION OF DOMESTIC AND EXOTIC SPECIES (FLAT-CUT RED OAK, MAPLE, CHERRY, MAHOGANY, WALNUT AND QUARTER-CUT ZEBRAWOOD, WENGE, BAMBOO)
- EUROPEAN FLAIR WITH WOOD GRAIN RUNNING HORIZONTALLY OR VERTICALLY
- STURDY, STABLE AND PERFECT MATCHING OF DOORS AND DRAWER FACES

20-4500-BA-89-15 (5/8")-~~526~~-F221-P87  
 20-4500-C-89-15 (5/8")-~~526~~-F108-P87  
 20-4500-E-89-15 (5/8")-F48-P87

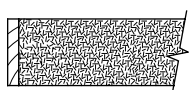

90-6600

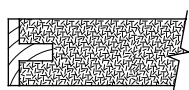

20-4500-89-15

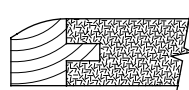

20-4500-89-15-P87

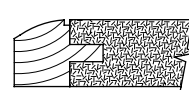

20-4500-89-15-~~526~~-P87

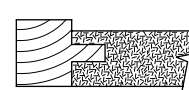

20-4500-458-15

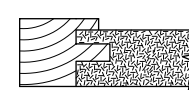

20-4500-458-05



**HERE COMES EURO<sup>3</sup>, THE THIRD GENERATION OF THE SLEEK, TRENDY EURO STYLE SERIES EXCLUSIVE TO CARON. ITS ATTRIBUTES—BUILT-IN HANDLES OR STEEL EDGES—BLEND PERFECTLY WITH CONTEMPORARY KITCHENS' STYLE AND ENHANCE THE RICHNESS OF THE WOOD GRAIN.**

OFFER YOUR CUSTOMERS AN EXCLUSIVE, SLEEK EUROPEAN-INSPIRED DESIGN AND FINE WOOD GRAIN (HORIZONTAL OR VERTICAL) IN ADDITION TO THE CONVENIENCE OF BUILT-IN HANDLES OR THE DURABILITY OF STEEL EDGES.

- ALSO AVAILABLE WITH WOODEN EDGE BAND
- RESOLUTELY CONTEMPORARY CLEAN LINES
- RICH VENEER (ON AN MDF CORE) OPTIMIZING NATURAL RESOURCES
- BUILT-IN HANDLES SO YOU SAVE ON HARDWARE
  - SOLID WOOD THAT MATCHES THE DOORS PERFECTLY
  - BRUSHED STAINLESS STEEL FINISH TO MATCH APPLIANCES
- FOUR-SIDED T-MOULDING IN SATIN-FINISH ALUMINUM
- DOMESTIC AND EXOTIC WOODS: BIRCH, MAPLE, CHERRY, WALNUT, WHITE OAK QUARTERSAWN, ZEBRAWOOD, TORRIFIED BAMBOO, WENGE, ETC.
- PERFECT MATCH DOORS / DRAWER FRONTS, RESISTANT, STABLE AND EASY TO MAINTAIN
- AVAILABLE WITH NATURAL FINISH OR IN A RANGE OF ATTRACTIVE COLOURS
- ALSO AVAILABLE: THE "DRIFTWOOD" OPTION FOR MORE TEXTURE (#990)



A - 20-4500-WE-89-13-[990](#)-F01  
 B - 90-6680-CQ-89-87-[537](#)-[990](#)-F131  
 C - 90-6680-CQ-89-93-[990](#)-F750

# EXOTIK STYLE

**IT IS FINALLY AFFORDABLE TO HAVE EXOTICISM AND BE ENVIRONMENTALLY RESPONSIBLE WITH THIS EXCLUSIVE COLLECTION FROM CARON. WITH THEIR UNIFORM COLOURS AND WOOD GRAINS, EXOTIK DOORS FOR CABINETS AND FURNITURE ARE A SUREFIRE DESIGN ELEMENT AS WELL AS A CHOICE THAT PRESERVES NATURAL RESOURCES. A GREAT OPTION FOR CLASSICAL AND CONTEMPORARY DECORS!**

DISPLAY YOUR ENVIRONMENTALLY RESPONSIBLE NATURE WITH THIS PRODUCT MADE OF PLANTATION WOOD, WHICH THEREBY HELPS TO PROTECT EXOTIC WOOD FORESTS. MADE OF ENGINEERED WOOD (OVER A RECYCLED WOOD CORE), THESE DOORS AND PANELS ADD VALUE TO ANY DECOR AT AFFORDABLE PRICE. MOREOVER, STAINING IS NOT REQUIRED. A SMART CHOICE FOR A WIDE VARIETY OF RESIDENTIAL, COMMERCIAL AND INSTITUTIONAL APPLICATIONS.

- ONE-PIECE, THREE-PIECE (VERSA) OR FIVE-PIECE (SHAKER) CONSTRUCTION
- WOOD SPECIES AVAILABLE: EBONY, WENGE, ZEBRAWOOD AND WHITE OAK (STRAIGHT-GRAIN, QUARTERSAWN)
- UNIFORM COLOURS AND WOOD GRAINS (HORIZONTAL AND VERTICAL)
- DIMENSIONAL STABILITY
- LOWER FINISHING COST (CLEAR FINISH AVAILABLE FOR \$3.95 PER SQ. FT. NET)
- FREE DELIVERY FOR 20 DOORS OR MORE\*

\*Conditions may apply.



80-6500-Z-458-87-F01



80-1200-CQ-20-03-917-F01



80-1200-WE-465-03-917-F01



80-1200-EB-465-03-917-F01

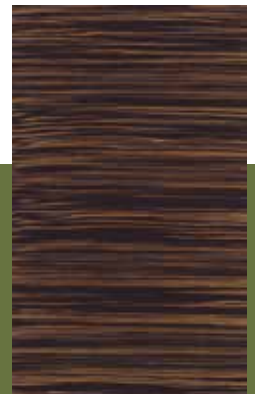

80-6000-EB-F01



Ⓐ - 20-6500-S-460-92-990-F01  
01



Ⓐ - 20-6500-I-458-87-990-F02



Ⓐ - 20-6500-F-460-92-990-F129  
01



Ⓐ - 20-6500-Z-458-87-F01



20-6500-CQ-447-03-F131



20-6500-CQ-448-03-F01



20-6500-T-405-87-F01



Ⓑ - 10-6500-R-87-413-591-F131



Ⓐ 20-6500-C-458-87-990-F77

# VERSA STYLE

20-6500-S-460-92-[990]-F01

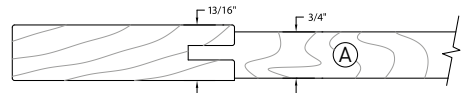

**CONTEMPORARY, RUGGED, NATURAL** LET CARON'S BRAND NEW VERSA STYLE DOOR COLLECTION CAPTURE YOUR IMAGINATION WITH ITS STUNNING VERSATILITY AND EUROPEAN FLAIR.

THESE SLEEK, THREE-PIECE CONSTRUCTION DOORS ARE DESIGNED WITH STYLISH HORIZONTAL GRAIN CENTER PANELS IN VENEER (A). DEPENDING ON WOOD TYPE CHOSEN, THEY CAN BE ENHANCED WITH A SELECTION OF OPTIONS SUCH AS TRENDSETTING "DRIFT WOOD", THAT ADDS A DISTINCTIVE THIRD DIMENSION TO THE WOOD'S NATURAL LOOK (IDEAL ON OPEN GRAIN WOOD AS PER OAK, ASH, FIR, ETC).

- AVAILABLE WITH THE WAVE OPTION ON MDF CENTER PANEL (#413) (B)
- OPTIMAL USE OF NATURAL RESOURCES (SHORT WOOD CUTS FOR CENTER PANELS)
- PERFECTLY COORDINATED DOORS AND DRAWER FACES
- AVAILABLE IN NUMEROUS COMBINATIONS: TEAK OR BAMBOO STYLES WITH ENVIRO PANELS, "DRIFT WOOD" OPTION ON PART OR ON THE ENTIRE DOOR (#990), ETC.
- DELIVERED TO YOU, FINISH SANDED OR PREFINISHED IN ATTRACTIVE COLORS



# MOZAIK STYLE

**A CARON-EXCLUSIVE, THE MOSAIK COLLECTION BRINGS NATURE RUGGEDNESS INTO THE HOME.** THESE MULTIDIMENSIONAL DOORS AND WALL PANELS ARE EXCELLENT FOR DESIGN APPLICATIONS AND COMPLEMENT SMOOTH SURFACES AND STAINLESS STEEL ACCESSORIES.

SPECIFY OUR EXCLUSIVE AND UNIQUE TEXTURED WOOD COMPONENTS TO YOUR CUSTOMERS. WOOD PIECES OF MULTIPLE LENGTHS, WIDTHS AND THICKNESSES ARE ASSEMBLED TOGETHER AS ONE CREATIVE ELEMENT. USED FOR CABINET DOORS, ISLAND, BACK SPLASHES, DECORATIVE WALL SECTIONS AND FURNITURE, THESE COMPONENTS ADD RUGGEDNESS AND WARMTH TO CONTEMPORARY DECORATIVE SETTINGS.

- MADE TO MEASURE AND AVAILABLE IN MOST WOOD SPECIES WITH OR WITHOUT STILES (HORIZONTAL OR VERTICAL PRESENTATION)
- OPTIMAL USE OF NATURAL RESOURCES
- RUSTIC, NATURAL, HOMEY FEEL WITH MULTI-TONAL COLORS
- BETTER ACOUSTIC PROPERTIES THAN FALSE STONES
- AVAILABLE RAW OR PREFINISHED NATURAL OR IN A WIDE RANGE OF COLORS

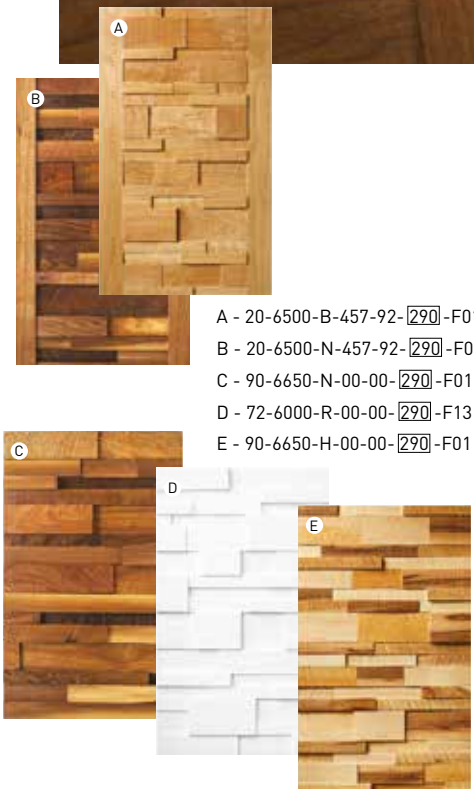

- A - 20-6500-B-457-92-290-F01
- B - 20-6500-N-457-92-290-F01
- C - 90-6650-N-00-00-290-F01
- D - 72-6000-R-00-00-290-F131
- E - 90-6650-H-00-00-290-F01





# OCEAN STYLE

**THE PURE LINES OF THE OCEAN COLLECTION PROVIDE YOU WITH A WAVE OF DESIGN POSSIBILITIES IN MULTIPLE DIMENSIONS.**

MADE OF PREMIUM MDF BOARDS, THESE DOORS OFFER A SMOOTH FINISH AND ADDED STABILITY. LET YOUR IMAGINATION FLOW!

YOUR CUSTOMERS WILL LOVE THESE TEXTURED DOORS AND WALL PANELS THAT CAN BE USED FOR MULTIPLE APPLICATIONS AND ADD FLAIR TO BOLD DECOR. THEY ARE AVAILABLE IN VERTICAL OR HORIZONTAL PRESENTATIONS AND ARE A UNIQUE DECORATIVE SOLUTION FOR BATHROOMS, CABINETS, ISLANDS, BACK SPLASHES, COUNTER OR BAR FRONTS, WALL FEATURES, ETC.

- MADE TO MEASURE, WITH OR WITHOUT STILES
- OPTIMAL USE OF NATURAL RESOURCES
- ZEN AND UNIQUE LOOK
- ACOUSTIC PROPERTIES
- AVAILABLE UNFINISHED, PRIMED ONLY OR IN A WIDE RANGE OF ATTRACTIVE OPAQUE COLORS



- A - 10-6500-R-00-87-[336](#)-F532
- B - 70-6000-R-00-00-[336](#)-F131
- C - 70-6000-R-00-00-[335](#)-F175
- D - 10-6500-R-00-87-[335](#)-F131
- E - 70-6000-R-00-00-[335](#)-F131



Door design :  
Drawer front design :  
Island panelling (front) :  
Appliance panel :  
Crown moulding :  
Wood type :  
Color :

# 20-1200-CQ-20-03  
# 35-1200-CQ-20-03  
# 20-1204B-CQ-20-03  
# 20-1200-CQ-20-03-530  
# 9542-CQ  
Quarter cut white oak  
# 449 brun automne





# TORRI STYLE

**NATURAL WOOD—EVEN BETTER** TORRI STYLE GRADE ADDS VALUE TO TRADITIONAL WOOD DOOR AND GIVES IT AN EXOTIC, CLASSY LOOK... AND IT'S COMPLETELY NATURAL PROCESS!

THE TECHNIQUE OF HEATING LUMBER UNTIL IT BECOMES ULTRA-DRY IS CENTURIES OLD BUT HAS ONLY BEEN COMMERCIALIZED RECENTLY, SO NOW YOU CAN ADD AFFORDABLE HIGHLIGHTS TO YOUR PROJECTS.

THE PROCESS RESULTS IN A RICHER, DARKER LOOK, NOT ONLY ON THE SURFACE BUT THROUGHOUT THE ENTIRE PIECE OF LUMBER.

- AVAILABLE IN WHITE ASH, BIRCH, AND KNOTTY PINE
- AVAILABLE IN MOST DESIGNS
- OPTIMAL AND ENVIRONMENTALLY FRIENDLY USE OF NATURAL RESOURCES
- **REDUCED FINISHING COST (NO STAIN REQUIRED)**
- DIMENSIONALLY STABLE AND IMPROVED RESISTANCE TO ROT/INSECTS
- INDOOR AND OUTDOOR APPLICATIONS



A - 10-1200-P (GR7)-302-01 (3'')-F01

B - 10-1200-F (GR7)-302-01 (3'')-F01

C - 10-1200-M (GR7)-302-01 (3'')-F01



Door design :	# 10-4500-E-04-01
Curved door design :	# 60-4500-E-04-01 R 12" Ext.
Open frame design :	# 15-4500-E-00-02- <u>800</u>
Curved open frame design :	# 61-4500-E-00-02- <u>800</u> R 12" Ext.
Drawer front design :	# 30-4500-E-14-01
Crown moulding :	# 9810-E
Curved crown moulding :	# 9850-E R 12"
Wood type :	Solid maple
Color :	# 188 Mustang



# CURVED

Caron's curved component selection is one of the most extensive of the industry. Available in numerous designs, types of wood, center panels, mouldings and configurations for ultimate personalization. While most are designed to cover either a full 1/4 or 1/8 circle, they can also be produced narrower or wider than indicated. In such case, make sure to indicate the chord needed in the radius of your choice. (Also available in custom radiuses.)

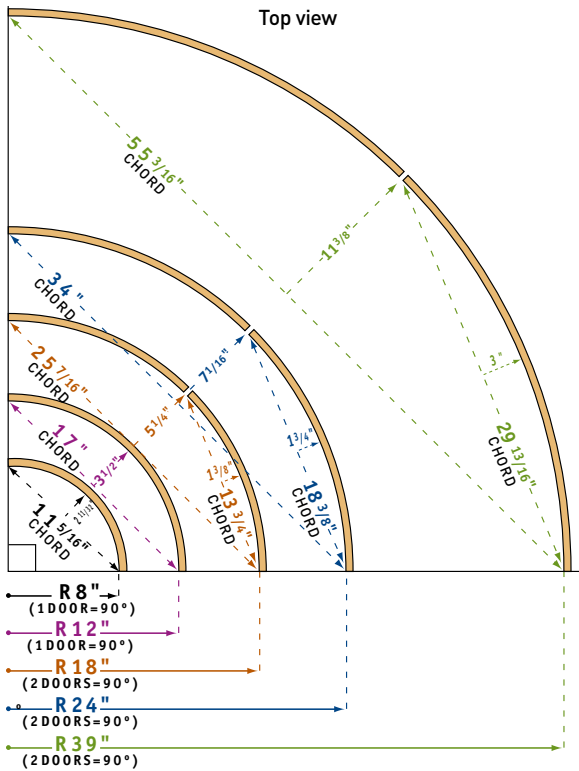

## Crown moulding

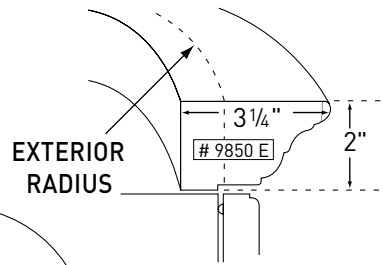

N.B.: Frame parts + valances also available.

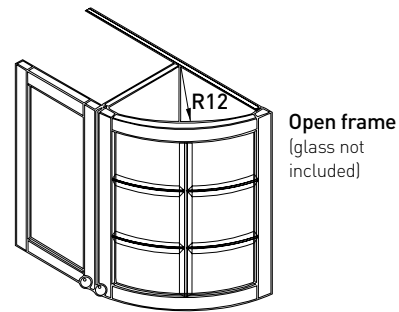
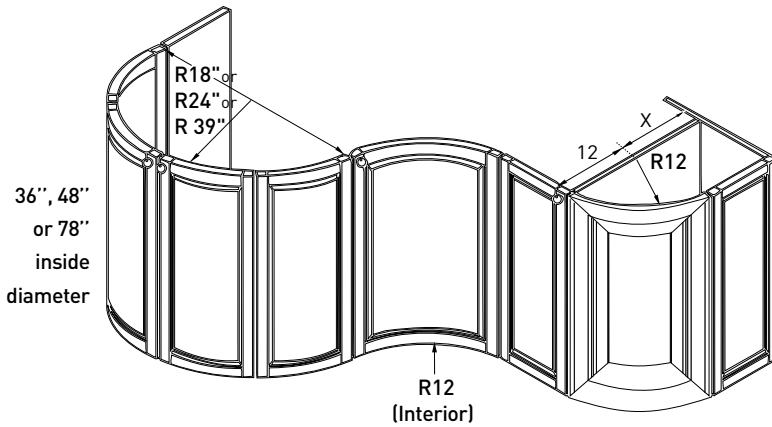
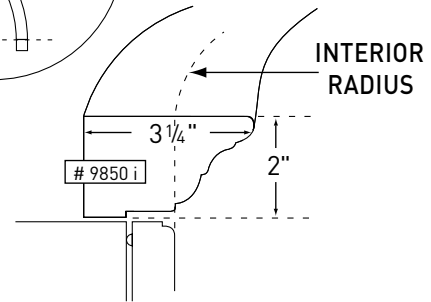

SPECIALTY COMPONENT



**Les Industries Caron (meubles) inc.**  
45, 4<sup>e</sup> Rue, Montmagny, C.P. 100  
(Québec) Canada G5V 3S3

**418.248.0255**  
**800.463.7060**

**418.248.0982**  
**800.463.3656**

Name					Client N°	By	Tel.: { }		Fax: { }				
Your P.O. #					Date	VIP Service: <input type="checkbox"/> NO <input type="checkbox"/> YES							
Delivery by					Special instructions								
GROUP #	DESIGN #	WOOD TYPE	GRADE	CENTER PANEL #	INTERIOR MOLDING #	OPTION #	EXTERIOR PROFILE #	FINISH #	CURVE INT. OR EXT.	HEIGHT	CHORD PER COMPONENT	RADIUS	QTY
ref. page 80	ref. page 80	ref. page 5-6	ref. page 4-5	ref. page 10	ref. page 11	ref. page 16-33	ref. page 11	ref. page 38-39-40	ref. page 61		ref. page 61	ref. page 61	
					#	width Rail Stile							

**IMPORTANT NOTICE :**  
We recommend to build cabinets (and order glass) after reception of your curved components.  
Look for this logo (c) on page 80 for availability in curved version.

Mesured on cabinet side



Door design :	# 10-1200-I-93-01 (3")- <u>700</u>
Drawer front design :	# 30-1200-I-313-01 (3" - 2 1/4")- <u>700</u>
Beaded pilaster :	# 90-6250-I-001
Vaulted appliqué :	# 90-8100-I-93-03
Leaf corbel :	# C1
Light valance :	# 9750-I-P03
Crown moulding :	# 9840-I
Wood type :	Solid Cherry
Color :	# 128 Blé d'automne



## VAULTED APPLIQUÉ, ANGLED

Available in most designs, with various configurations using raised, recessed or M.D.F. panels. Make sure to specify the width of each segment, depth and degree (if applicable). We recommend to build the cabinets after reception of these components.

Vaulted appliqué for hood range or other feature cabinet.

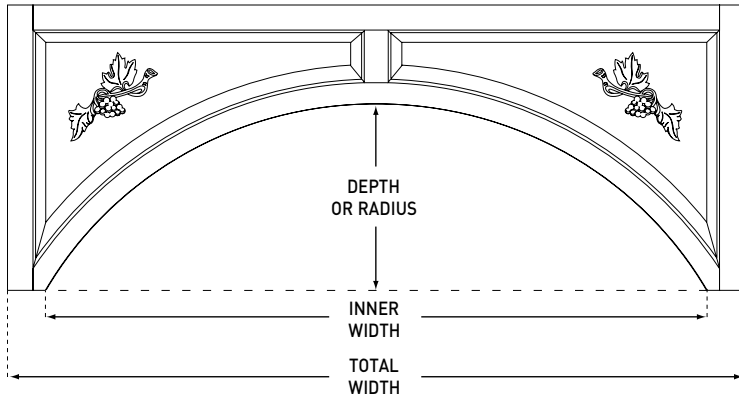

90-8100-06-01

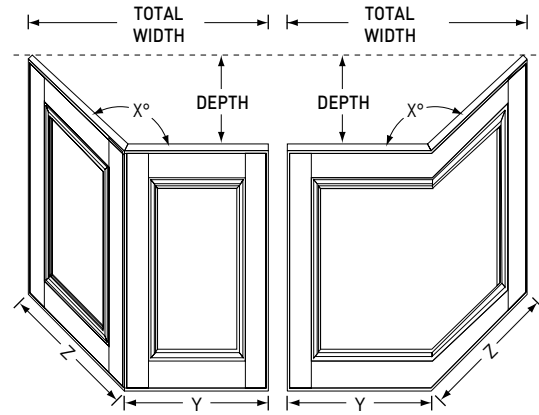

90-8000-02-01  
(with middle stile)

90-8000-02-01  
(no middle stile)

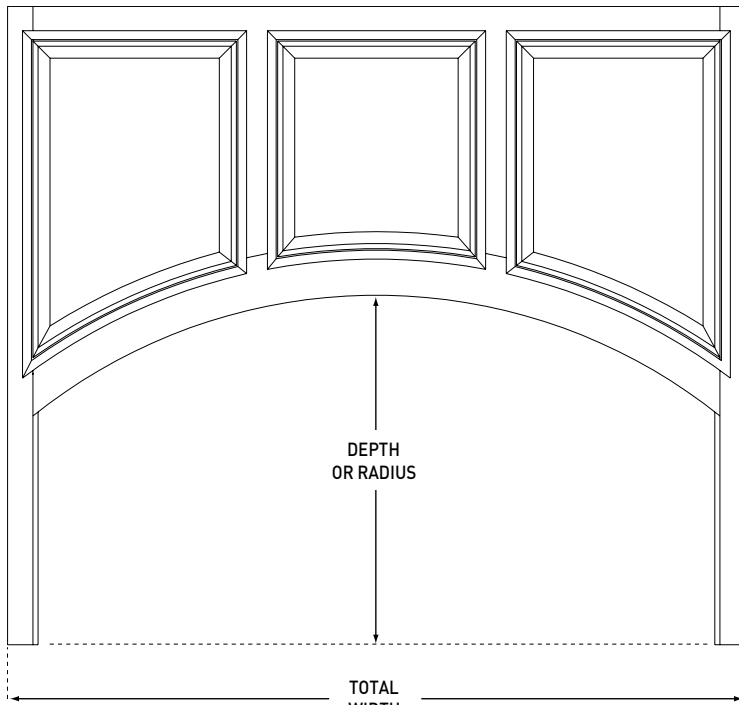

90-8100-05-01-700

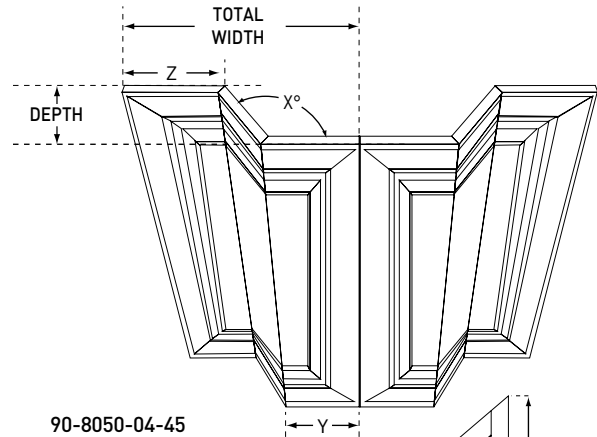

90-8050-04-45  
«Z» doors

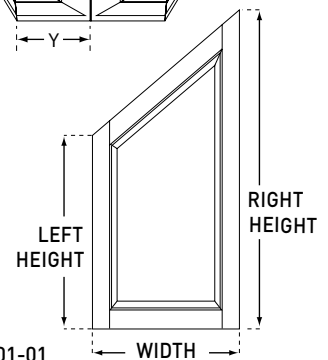

90-8150-01-01  
Special application angled door

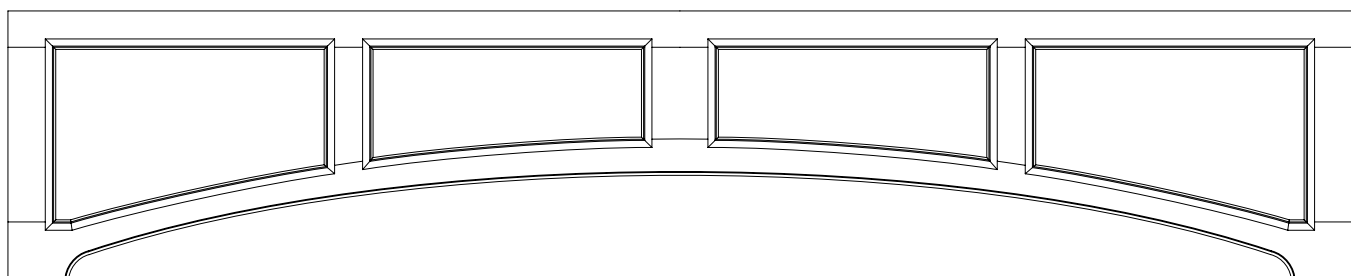

90-8100-10-09-700



Door design : # 10-1200-ES-24-09  
Drawer front design : # 30-1200-ES-24-09  
Beaded inset frame : # 15-1200-ES-00-04-252  
Beaded moulding : # 9820-ES  
Crown moulding : # 9860-ES  
Wood type : Solid Silver Maple  
Color : # 169 ardoise



## APPLIANCE PANEL

Most door designs can be used as appliance panels for an exquisite integrated look. Make sure of compatibility with your appliances (special adapters supplied) and specify the appropriate option.

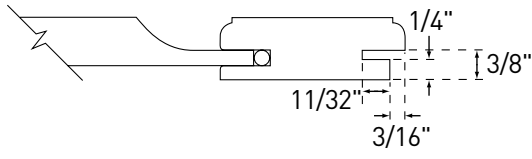

Option **530** P02

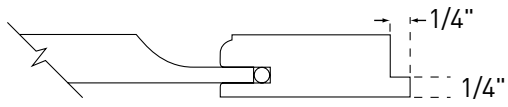

Option **532**

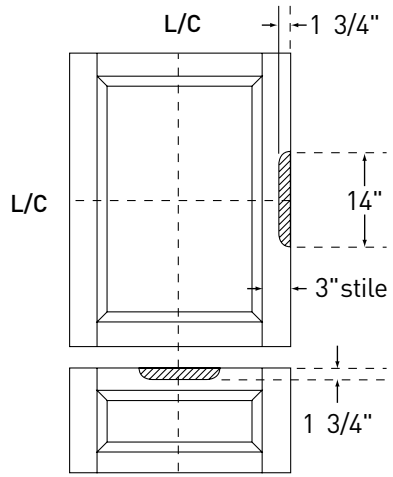

Option **534** (on stile)

Option **536** (on crosspiece)

## FACE FRAME

Available in multiple configurations. Make sure to indicate stile + crosspiece widths and position (if not equal openings) along with outside measurements.

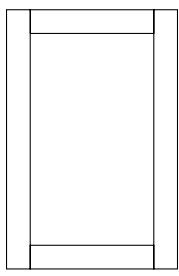

15-1200-00-04

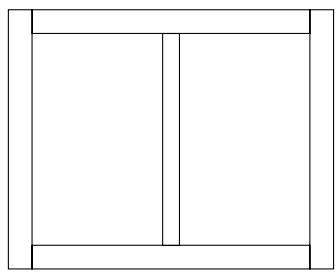

15-1202B-00-04

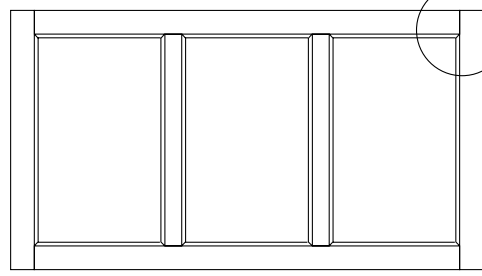

15-1203 B-00-04-**252**

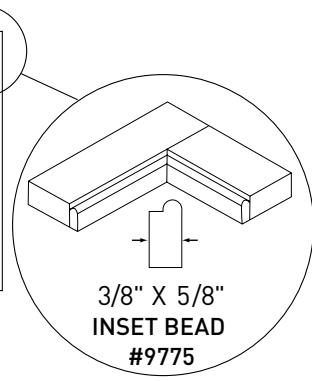

Also available installed on the inside edge of face frame opening (for flush fit cabinetry)  
Option # **252**

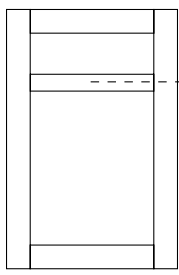

15-1202 A-00-04

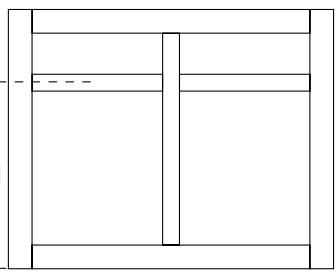

15-1204 C-00-04

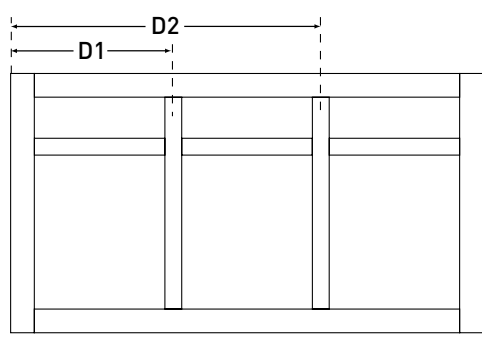

15-1206 Y-00-04



Door design (uppers) :

Door design (lowers) :

Drawer front design :

Turned wooden Post :

Toe kick :

Wood type :

Colors :

Laminated wood top :

Dovetail drawer box (front exposed) :

# 10-1202T-E-313-03-800-405-P20

# 10-1200-E-313-03-405-P20

# 30-1200-E-313-03-P20

# 90-6300-E-

# 90-9500-E-002-P01

Rustic maple (no color watch)

F131, F20 on walnut

# 90-4060-N-F20

# 90-6055-E-DEGP02-P20



**CROWN MOULDING, BASE MOULDING, LIGHT VALANCE**

Please refer to page 11 to see more mouldings and edge treatments. They can be used as decorative elements, valances, counter top edges etc. (base moulding + door trims 3/8" to 3/4" thick). Also available with groove as door part to be used with Caron's adaptor # 9809 to create crown mouldings which perfectly match your project's door style. (Choose required interior moulding number and add 00\* before.) Ask for our designer collection (Ref. Pages 11 and 77) to receive samples of our most popular mouldings.

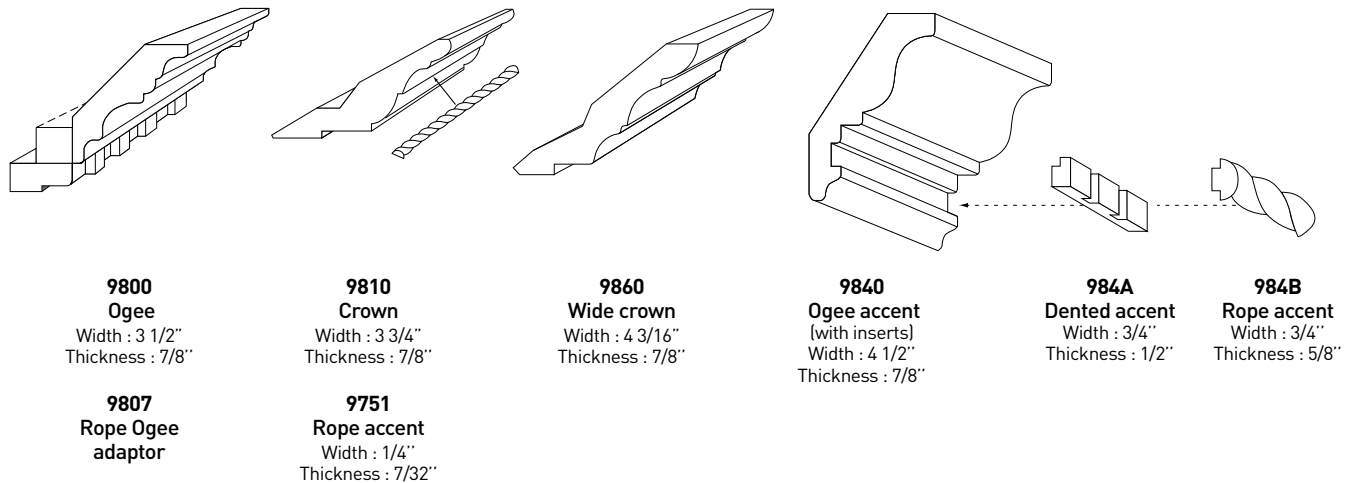
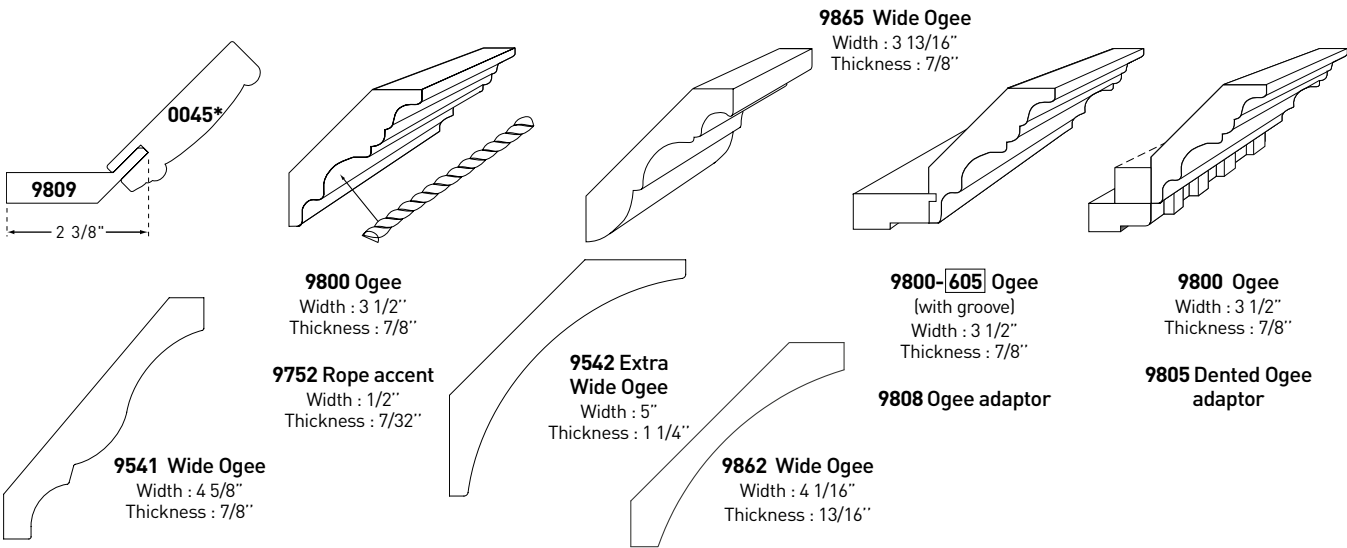
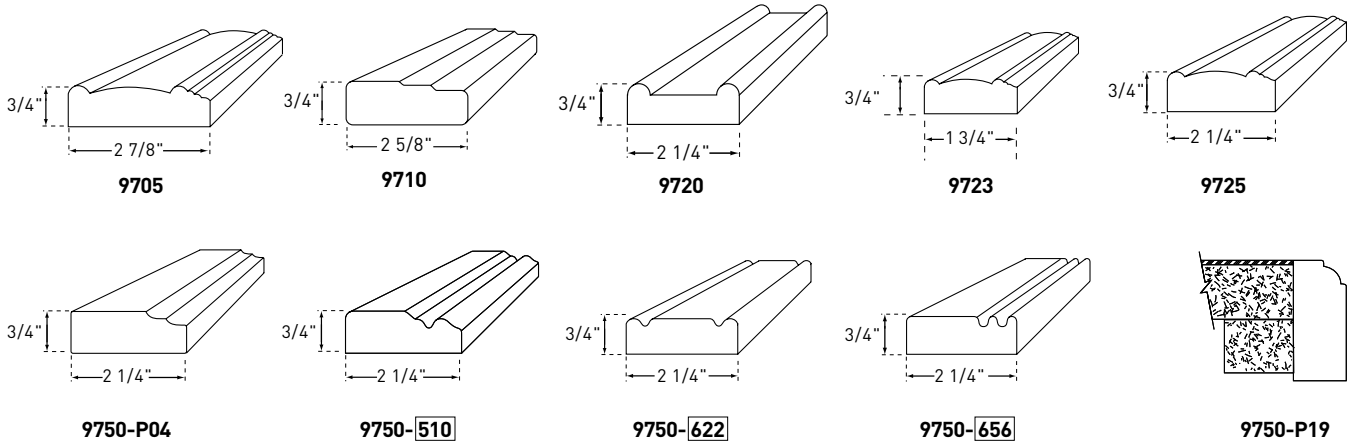



Door design : # 10-1200-E-06-01-(3 3/8")-700-P20  
Open frame design : # 15-1200-E-00-02-(3 3/8")-700-P20  
Turned wooden post 2" : # 90-6300-E  
Crown moulding : # 9840-E #984A-E  
Architectural wood carving : # 90-9350-E  
Wood type : Solid maple  
Color : # 124 espresso

Several of these mouldings can be applied on our doors (ref. pages 20-32). They can also be used as a complement elsewhere on your projects.



**ACCENT**

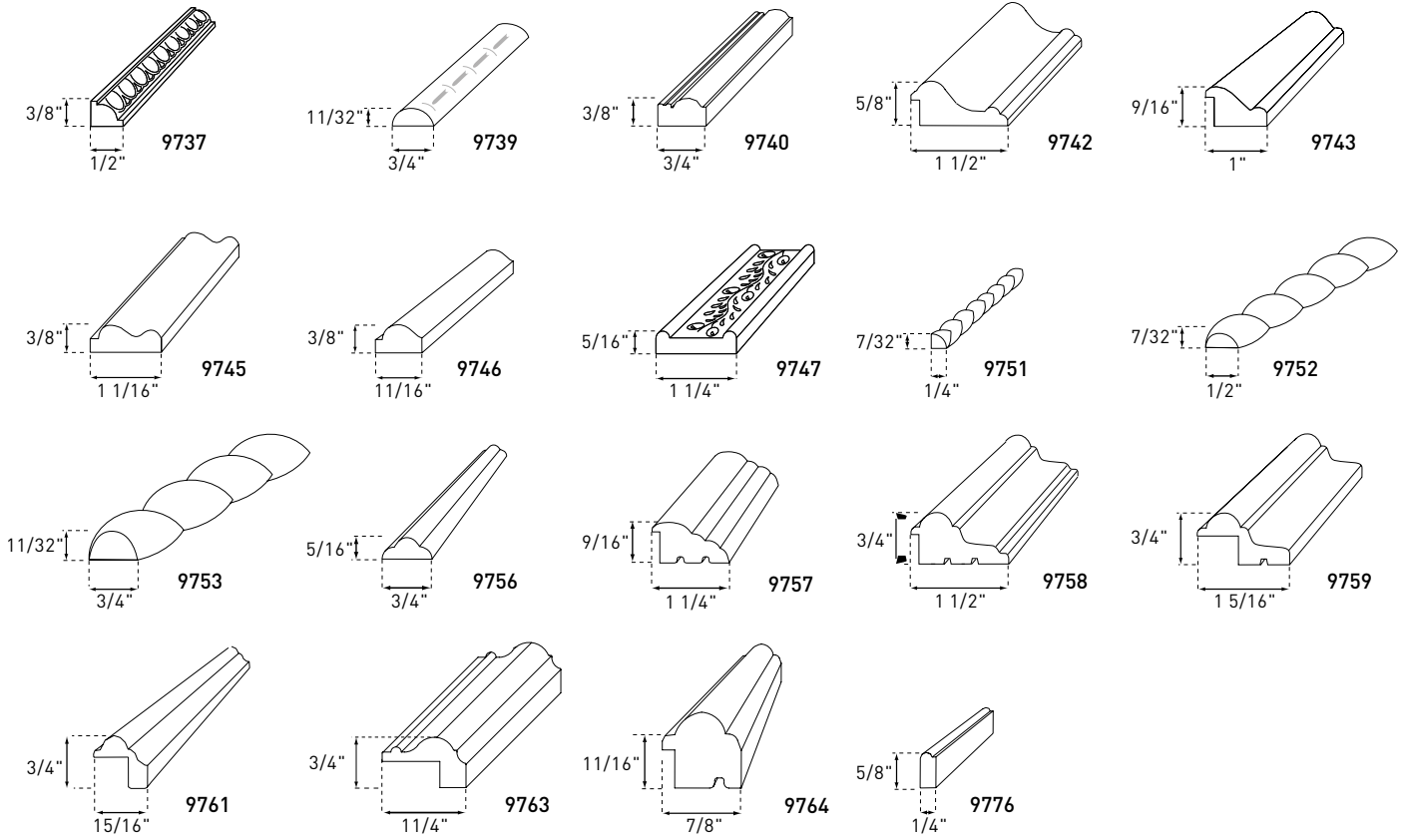

**JOINT COVER / CORNER**

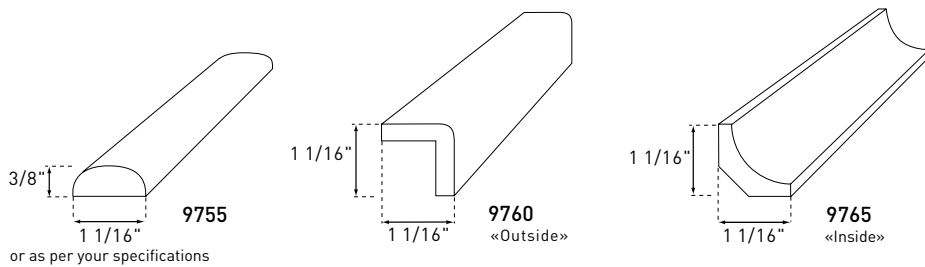

**BEAD**

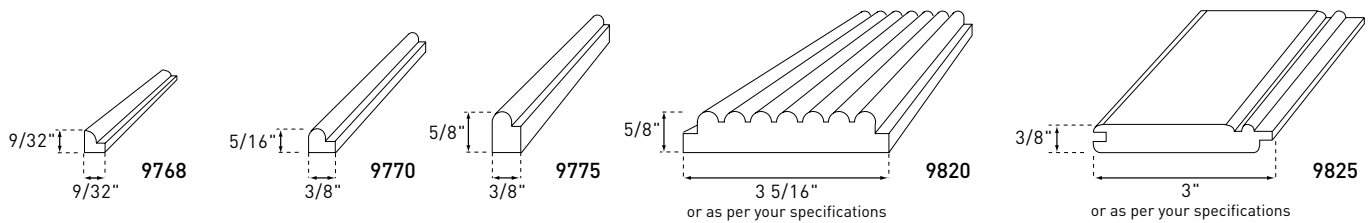

**OTHER**

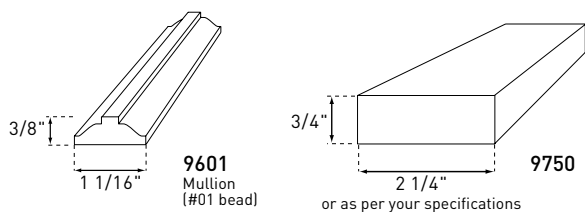



Door design : # 10-4500-I-04-21  
 Open frame design : # 15-4500-I-00-21  
 Drawer front design : # 30-4500-I-04-21  
 Drawer front design (small) : # 35-4500-I-20-20  
 Crown moulding : # 9865-1  
 Leaf corbel : # C1-I 999  
 Wood type : Solid cherry  
 Color : # 135 Miel doré



**C30 Small leaf corbel**  
 Height : 6 3/4"  
 Width : 3 1/2"  
 Depth : 3 3/4"

**C1 Leaf corbel**  
 Height : 9 7/8"  
 Width : 4 3/4"  
 Depth : 5 1/2"

## ARCHITECTURAL WOOD CARVING

These carvings are kept in stock for optimal service and pricing. It is only an introduction to Caron's extensive custom program. We welcome your designs, pictures and specifications so we can produce exclusive hand carvings for you in the wood type of your choice.



ACCESSORY



**C31 Small grape corbel**

Height : 6 3/4"  
Width : 3 1/2"  
Depth : 3 3/4"

**C2 Grape corbel**

Height : 10 1/4"  
Width : 5 1/8"  
Depth : 5 1/2"

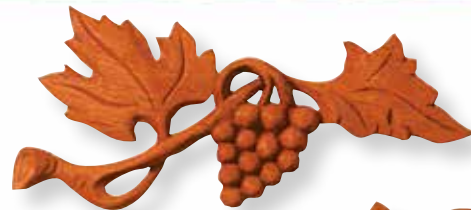

**C3 Left / right grape**

Height : 3 1/2"  
Width : 8"  
Thickness : 1/2"



**C5 Grape only**

Height : 7"  
Width : 6"  
Thickness : 1 1/4"



**C4 Bow**

Height : 2"  
Width : 8"  
Thickness : 1/2"





# TOP STYLE COLLECTION

**50%\***

WHICH ITS PRACTICAL ENVIRONMENTALLY FRIENDLY CARRYING CASE AND 10 SAMPLES OF OUR MOST POPULAR LAMINATED SURFACES. LIKE NEVER BEFORE, YOU NOW CAN MAKE EXCLUSIVE COMBINATIONS AND PROJECTS. HAVE EVERYTHING AT HAND WITH THE NEW CARON TOP STYLE COLLECTION. TAKE ADVANTAGE OF OUR INTRODUCTORY OFFER AND GET IT SHIPPED TO YOU AT 50%\* OFF LISTED PRICES, SHIPPING AND HANDLING INCLUDED.

\* LIMITED TIME OFFER / CONDITIONS MAY APPLY

CARONINDUSTRIES.COM



Island top : 90-4060 P903    Jointed solid walnut  
 Color: # 780                      Mineral oil (food grade)



Island top : 90-4060                      2 1/2" thick, face glued top wormy maple  
 Background : 90-4060                      1 3/4" thick, face glued top black walnut  
 Color: # 780                                  Mineral oil (food grade)



# TOP STYLE

**WOOD COUNTERTOPS—THE CLASSIC KITCHEN COOKMATE** WOOD'S WARMTH, RICHNESS, AND DURABILITY ARE PERFECT FOR THE KITCHEN. WITH THE TOP STYLE COLLECTION OF LAMINATED SURFACES, YOU CAN MAKE WOOD AN EVERYDAY ACCESSORY THAT COMPLEMENTS YOUR DECOR AND SHOWS YOUR ECO-FRIENDLY SIDE. LIKE GREAT CHEFS, OPT FOR THESE PRACTICAL WOOD WORK SURFACES.

DESIGNED TO GIVE KITCHEN ISLANDS, FURNITURE, OR COUNTERTOPS A UNIQUE LOOK ALL OF THEIR OWN, TOP STYLE LAMINATED SURFACES ARE DURABLE, DISTINCTIVE, AND AFFORDABLE. AND SINCE THEY ARE MADE ENTIRELY OF SOLID WOOD, A RENEWABLE RESOURCE, THESE TOPS ARE ECO-FRIENDLY TOO—A QUALITY SURE TO ENHANCE THE NATURAL WARMTH AND BEAUTY WOOD GIVES TO ANY INTERIOR DESIGN.

- AMAZINGLY AFFORDABLE
- AVAILABLE IN MOST WOOD SPECIES (SEE WOOD SELECTION PAGES 6, 77)
- AVAILABLE EDGE GRAIN OR END GRAIN CONSTRUCTION (FOR CUTTING SURFACE)
- LIVE EDGE ALSO AVAILABLE
- DIMENSIONS, WIDTH, PROFILES, EXTERIOR CUT (OR INTERIOR FOR SINKS) TO YOUR SPECIFICATIONS
- DELIVERED READY FOR FINISHING OR PREFINISHED (WITH MINERAL OIL OR WITH ONE OF THE MANY FINISHES IN OUR COLOR SELECTION (REF. PAGES 38, 77)
- FREE SHIPPING\*

- 90-4050-JA-F780-P903
- 90-4060-N-F780-P901
- 90-4060-P-gr6-999-F780-P902
- 90-4060-E-6/4-F780-P52
- 90-4060-T-F780



Optional "Live edge"







Dovetail drawer box  
(with dividers) : # 90-6050-E-07  
Drawer front design : # 35-4500-E-53-19-549  
Dovetail drawer box  
(handle cut out) : # 90-6050-E-P0  
Dovetail drawer box (basic) : # 90-6050-E  
Wood type : Solid maple, cherry  
Color : # 01

**PERSONALIZE YOUR PROJECTS**

Use laminated wood, turned wooden posts, valances, pilasters, plate holders, etc. Most of these accessories are available in the wood type and dimensions of your choice. Some of these accessories can be personalized with your company name or logo\*. The ideal gift with your customers new kitchen (\*conditions may apply)

**90-9100**  
**Plywood for end gable**  
 (7/32" thick) 96" x 48"

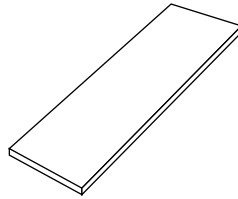

**90-9200**  
**Flexible wood skin (premium grade)**  
 (Polyback 0.035") 96" x 48"

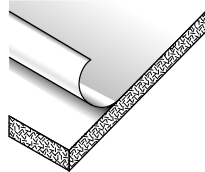

**New**

**90-6600**  
 3/4" thick edge banded plywood for end gables cut to your specifications. Ideal with prefinished doors (5/8" thick = 90-6650)

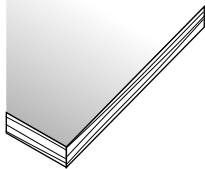

**90-4060**  
**Laminated solid wood**  
 (Edge grain)

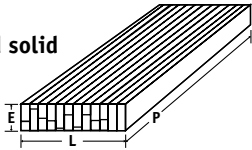

**90-4050**  
**Butcher block**  
 (End grain)

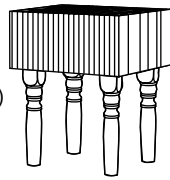

**Fret work / valance**  
 Available in most wood types and sizes. Caron's classic fret work can be surface routed only or through the board for maximum contrast (open version). Fret work and valance are readily available with or without edge treatment (Ref. Page 11).

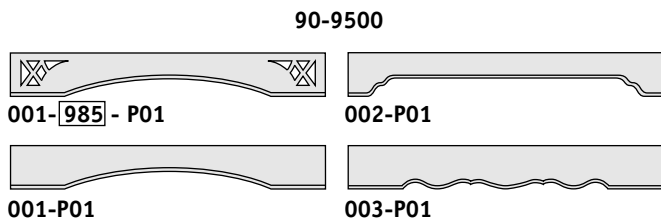
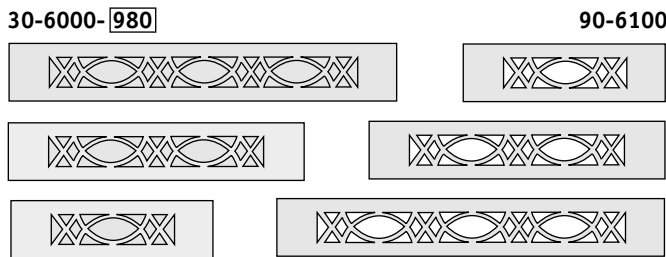

**90-9630\***  
**Cutting board**  
 15 3/4" x 11 3/4" x 1 1/4"



**90-9630\***  
**Bread board**  
 24" x 5" x 5/8"



**91-9600\***  
**Book stand**  
 12" x 11 7/8" x 5/8"

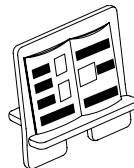

**90-9630\***  
**Knife block**  
 11 1/4" H x 6 3/4" L x 6" P

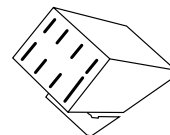

**91-9600\***  
**Pizza Boards**  
 15 1/8" x 10"



**90-6250**  
**Pilaster / filler**

**001**  
**Beaded**

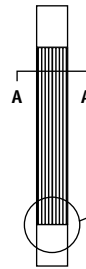

SECTION AA

**002**  
**Fluted**

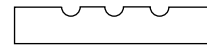
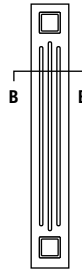

SECTION BB

**003**  
**Fluted plus**

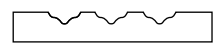
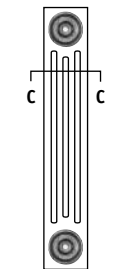

SECTION CC

**90-6300**  
**Turned wooden post**

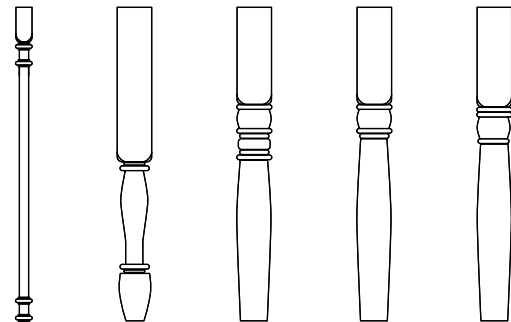

**90-2030**  
**Plate holder**

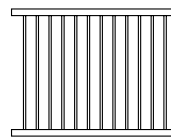

**90-2000**  
**Wine rack**

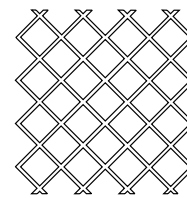

**90-9630**  
 Clear vinyl moulding (glass retainer) included with most open frames. Available by the roll (1000 lineal feet).

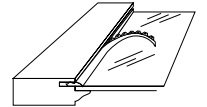

Designed to help you help your clientele, these promotional materials are practical, powerful and professional. Most are offered with 50 % off the catalogue price, shipping included\*.



**91-9600**

**Showroom tower package (Doors to be ordered separately)**

Ideal for maximum visual impact and to show doors with matching fronts. Dovetail drawer box as base, the three faces tower rotates and are capped with a solid wood laminated top.

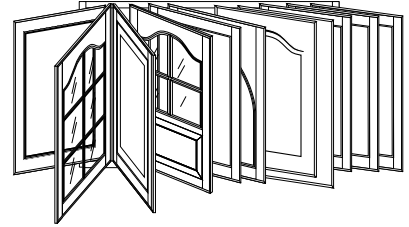

**Display kit**

*Ideal for showrooms with limited wall space.*

26" high x 36" wide

Including up to 13 doors (24"H x 14 1/2" W). Either your own selection of designs, wood types or Caron's selection. Comes with mounting bracket, spacers and screws.

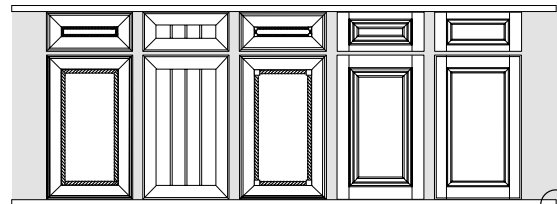

**For showrooms with more wall space**

You can use our convenient « T » moulding (# 9510) to hold your door selection. This specific application allows you to pull doors out easily and also to show a « drawer above door » situation.

**91-9600**

**Leather case**

13" high x 18" wide x 7 3/4" deep

Ideal for on site presentations.

Can hold 9 doors (16"H x 11 1/2"W).



**90-9600**

**Wood Selection**

Discover Caron's exclusive selection including more than 40 different prefinished (natural clear) solid wood samples in a practical architect's folder;

- 22 classics
- 11 Exotics
- 11 Green / Reclaimed



# 9510

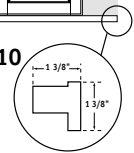

**90-9600**

**Color Selection**

Practical architect's folder including 63 color samples on solid wood coordinated with popular melamine board colors;

- 20 Stains
- 16 Glazed
- 19 Solid colors
- 8 Primers

New

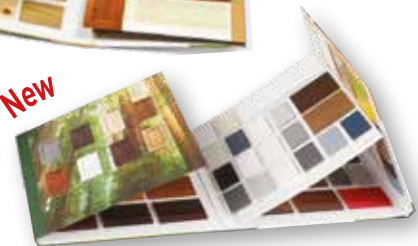

**90-9600**

**Top style collection**

Get 10 samples of our most popular laminated surfaces in a convenient carrying case

**90-9600**

**Designer Collection**

Now more complete and « greener » than ever in a handy ecological carrying case which showcases close to 100 components :

- 24 center panel corners
- 22 exterior profiles
- 25 interior mouldings
- 21 decorative mouldings



**90-9600**

**Shaker 3.0 collection**

8 door sections in a convenient carrying dovetail drawer box



New

**90-9600**

**EURO LAM collection**

23 laminated MDF door sections showing different mouldings in various colors/textures in a convenient carrying case.

Also available separately :

- moulding selection
- Color / texture selection
- Accessory selection

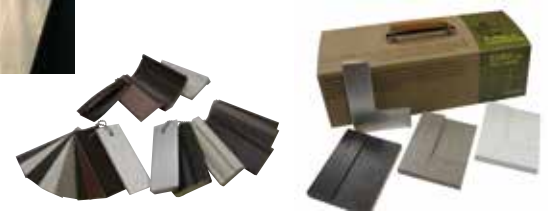

**91-9600**

**Literature**

Caron offers a vast array of literature to assist you. Updates are sent regularly. Feel free to contact us for additional copies;

- Corporate brochure
- Creation and design guide
- Shaker 3.0 brochure
- EURO LAM Brochure
- Poster
- Promotional brochure
- Order form, etc.



\* Conditions may apply.

**EASY + EXPEDITED  
ON LINE  
ORDERING**  
Ask for your access code



**10-1200-AR-S-313-03-406-110-F911-P02**

<b>Group</b> <b>10</b> solid raised door Ref. page 80	<b>Design</b> <b>1200</b> square Ref. page 80	<b>Wood type</b> <b>AR</b> Red Alder Ref. pages 4-5-6	<b>Grade</b> <b>S</b> Select Ref. pages 4-5	<b>Center panel profile</b> <b>313 ECO</b> Ref. page 10	<b>Interior moulding</b> <b>03</b> Ref. page 11	<b>Options</b> <b>406-110</b> Bead + applied moulding Ref. pages 16-33	<b>Finishing</b> <b>F911</b> Rocheuses Ref. pages 38-49	<b>Exterior profile</b> <b>P02</b> Ref. page 11
--	--	--	--	---	---	---	--	---

**HOW TO ORDER**

On line: ask for your user name + password. For assistance or any questions: 1.800.463.7060  
 Or view the on line ordering video in our Web Site (Secured section)  
 Or use this 7 step check list;

1. Get familiar with Caron's Guide and brochures.
2. Use Caron's order/quotation forms (they can be supplied to you at no cost or you can make copies of the next page). You may also order on line at caronindustries.com.
3. Indicate proper codes and numbers (referring to corresponding pages as mentioned above or on the order form).
4. For assistance or any questions: 1 800 463-7060 or view our video "How to order" in our Web Site (Secured section)
5. Indicate clearly if this request is an order or a quotation (check appropriate box at bottom of page).
6. Forward your request via:
  - FAX: 1.800.463.3656
  - EMAIL: orders@caronindustries.com
  - ONLINE: caronindustries.com
7. Double check carefully all key information on the order confirmation: to be signed only if there are no modifications.

Co. Name			Client #		Name		Tel.: ( ) Fax: ( )				
Your P.O. #			Ordering date			VIP Service: <input type="checkbox"/> NO <input type="checkbox"/> YES					
Delivery by			Special instructions								
<b>DOORS</b>	Group #	Design #	Wood Type	Grade	Central Panel #	Interior Moulding # Ref. page 11		Option #	Finish #	Exterior Profile #	
	Ref. page 80	Ref. page 80	Ref. pages 5-6	Ref. pages 4-5	Ref. page 10	#	Width RAIL STILE		Ref. pages 16-33	Ref. pages 38-49	Ref. page 11
	HEIGHT x WIDTH				QTY		HEIGHT x WIDTH				QTY

**TOTAL**

<b>DRAWER FRONTS</b>	Group #	Design #	Wood Type	Grade	Central Panel #	Interior Moulding # Ref. page 11		Option #	Finish #	Exterior Profile #	
	Ref. page 80	Ref. page 80	Ref. pages 5-6	Ref. pages 4-5	Ref. page 10	#	Width RAIL STILE		Ref. pages 16-33	Ref. pages 38-49	Ref. page 11
	HEIGHT x WIDTH				QTY		HEIGHT x WIDTH				QTY

**TOTAL**

<b>MOULDINGS</b>	Model #	Wood Type	Grade	Option	Width	Finish #	Qty
	Ref. pages 11, 66-69	Ref. pages 5-6	Ref. pages 4-5	Ref. pages 16-33		Ref. pages 38-49	

ORDER                       QUOTATION

**GROUP # AND DESIGN #**

These two first specifications are the most important as they define the nature of the selected component. Thus, the group number indicates whether it is a door, drawer face, etc. and the design number defines its configuration: square, arched, etc.

Please refer to pages 4, 5 and 6 for complete description of grades and wood types available, pages 34 and 36 for most popular multi panel door configurations.

**GROUP**

<b>Group #</b>		<b>page</b>
10	Solid raised door.....	80
15	Open frame .....	15
20	Flat panel door*.....	80
30	Solid drawer front.....	80
35	Flat panel drawer front*.....	80
50	Moulding (various lengths).....	66
60	Curved door .....	60
61	Curved open frame .....	60

<b>Group #</b>		<b>page</b>
62	Curved drawer front .....	60
63	Curved moulding .....	60
70	MDF door (medium density fiberboard).....	42
71	MDF open frame .....	42
72	MDF drawer front .....	42
80	Engineered wood components (Exotik).....	53
85	Laminated MDF (Eurolam) .....	46
88	Laminated MDF (Brilliant) .....	48
90	Miscellaneous / Accessory.....	62

**DESIGN**

GROUP #	DESIGN #	DESCRIPTION
10	1200	Solid raised door square design (c)
10	1202	Solid raised door square design, 2 panels (c)
10	1203	Solid raised door square design, 3 panels (c)
10	1204	Solid raised door square design, 4 panels (c)
10	1205	Solid raised door square design, 5 panels (c)
10	1206	Solid raised door square design, 6 panels (c)
10	1300	Solid raised door arch design (c)
10	1302	Solid raised door arch design, 2 panels (c)
10	1370	Solid raised door arch design plus (c)
10	1600	Solid raised door arch design, top & bottom (c)
10	1670	Solid raised door arch design plus, top & bottom (c)
10	1800	*Solid door 1" horizontal batten
10	1900	*Solid door 2" horizontal batten
10	1970	*Solid door 3/4" closed lover
10	3000	Solid raised door vaulted design plus (c)
10	3060	Solid raised door vaulted design plus, top & bottom (c)
10	3100	Solid raised door vaulted design (c)
10	3150	Solid raised door vaulted design, left/right (c)
10	3160	Solid raised door vaulted design, top & bottom(c)
10	3200	Solid raised door half circle design
10	3300	Solid raised door quarter circle design, left/right
10	3400	Solid raised door arch design, left/right (c)
10	3700	Solid raised door gothic plus design
10	3750	Solid raised door gothic design
10	4500	Solid raised door assembled 45°, regular moulding (c)
10	4500	Solid raised door assembled 45°, convex moulding (c)
10	4550	Solid raised door 45°, corner 22.5°, left/right

GROUP #	DESIGN #	DESCRIPTION
20	1200	Flat panel door square design
20	1202	Flat panel door square design, 2 panels
20	1203	Flat panel door square design, 3 panels
20	1204	Flat panel door square design, 4 panels
20	1205	Flat panel door square design, 5 panels
20	1206	Flat panel door square design, 6 panels
20	1300	Flat panel door arch design
20	1302	Flat panel door arch design, 2 panels
20	1370	Flat panel door arch design plus
20	1600	Flat panel door arch design, top & bottom
20	1670	Flat panel door arch design plus, top & bottom
20	3000	Flat panel door vaulted design plus
20	3060	Flat panel door vaulted design plus, top & bottom
20	3100	Flat panel door vaulted design
20	3150	Flat panel door vaulted, left/right
20	3160	Flat panel door vaulted, top & bottom
20	3200	Flat panel door half circle design
20	3300	Flat panel door quarter circle design, left/right
20	3400	Flat panel door arch design, left/right
20	3700	Flat panel door gothic plus design
20	3750	Flat panel door gothic design
20	4500	Flat panel door assembled 45°, regular moulding
20	4500	Flat panel door assembled 45°, convex moulding
20	4500	Flat panel door 3/4" "Euro plus"
20	5000	Flat panel door 3/4" rift cut

30	1200	*Solid raised drawer front 5 pieces ** (c)
30	1202	*Solid raised drawer front 7 pieces (2 panels) ** (c)
30	1800	*Solid drawer front 1" horizontal batten
30	1900	*Solid drawer front 2" horizontal batten
30	1970	*Solid drawer front 3/4" closed louver
30	4500	*Solid raised drawer front assembled 45°, regular moulding (c)
30	4500	*Solid raised drawer front assembled 45°, convex moulding (c)
30	6000	*Solid slab drawer front plain (c)

35	1200	*Flat panel drawer front 5 pieces **
35	1202	*Flat panel drawer front 7 pieces (2 panels) **
35	4500	*Flat panel drawer front assembled 45°, regular moulding
35	4500	*Flat panel drawer front assembled 45°, convex moulding
35	4500	*Flat panel drawer front 3/4" "Euro plus"
35	5000	*Flat panel drawer front 3/4" rift cut

90	6400	7/8" Flat panel door/drawer front "pillow"
90	6600	3/4" Thick edge banded end gable
90	6650	5/8" Thick edge banded end gable

\* Horizontal grain center panel  
 \*\* 1 5/8" crosspieces (except otherwise specified)

\* Veneered center panel (on MDF or particule core depending on supply)  
 (c) : Available in curved version (Ref. Pages 60, 61)

**New**



## MINIMUM AND MAXIMUM SIZE

Even though we produce components up to 10' tall by 5' wide, maximum sizes vary depending on design and wood type chosen. As a general rule, we suggest to use two or more components that you fasten together instead of a very large single one. This is to minimize freight damage, increase product stability and ensure you better guarantee coverage.

As for minimums, Caron offers so many possible combinations that it would be very difficult to confirm them all. However, this catalogue contains all information needed to find most of them.

**Minimum width** Solid raised door example :

$(\text{width of stile} \times 2) + (\text{center panel reveal} \times 2) + (1/2'' \text{ center panel flat section}) = \text{minimum width}$

**Minimum height** Solid raised drawer front example :

$(\text{width of crosspiece} \times 2) + (\text{center panel reveal} \times 2) + (1/2'' \text{ center panel flat section}) = \text{minimum height}$

**IMPORTANT NOTICE :** Please refer to pages 10 and 11 for center panel reveals and moulding widths.

For all minimums do not forget to add the width of the accent moulding x 2 for any option applied on center panel.

To lower minimum heights on drawer fronts :

- Reduce crosspiece width (Ref. Page 80\*\*)
- Reduce center panel reveal (Ref. Page 10)
- Reduce center panel flat section (according to knob or handle back plate specifications)
- Reduce applied moulding width (if applicable)

## PRODUCTION TIME

Caron's short estimated production time will be confirmed on each one of your orders or quotations. Please take notice production time starts after reception of your final confirmation and after credit approval. This does not include transit time nor does it include weekends, statutory holidays and / or things beyond our control such as major storms and power failures, etc.

*N.B. Estimated production time varies depending on design, wood type and options ordered. It may also vary during the year according to the demand.*

### Rush orders / V.I.P. service

For emergencies, estimated production time can be reduced by half\*. Ask for our V.I.P. service to get all details. (\* Conditions may apply.)

### Info shipping service

To facilitate your planning, Caron's exclusive info shipping service will let you know each time an order is leaving.

### Free\* delivery service

Orders of 20 doors and more (6000 series, end gables and other restrictions may apply).

\*Basic freight dock to dock. Any additional service/fees at customer's expense.

**GUARANTEE OF SATISFACTION**



- Inspect goods upon reception.
- In case of shortage, damage or non conformity, make note on the bill of lading before signing. Check contents for shortage, accuracy and concealed damage. Notify us within 24 hours of any discrepancies. Failure to follow these steps relieves CARON and the carrier of all shipment responsibilities.
- Once above steps completed, ask for an authorization number prior to sending anything back. (Always use original packaging.)
- Broken and / or non conform components will be replaced and / or repaired within the shortest possible time.
- Make sure to finish the goods A.S.A.P. if not purchased already prefinished.
- To reduce warpage, shifting or splitting of wood, avoid sharp changes in temperature and keep relative humidity between 30% and 40%.

Components over 45" high will automatically be made WITHOUT middle crosspiece unless specified otherwise. Ask for a middle crosspiece for warpage guarantee coverage of more than 9/32". (Valid up to one month after date of shipping.)

Components over 45" high with no middle crosspiece will carry no guarantee. In some cases, the use of two doors is recommended.

Any component over 26" wide requires a middle stile to be guaranteed.

- Tolerance for dimension :**                    **± 1 mm on exterior measurement**  
    **± 2 mm on parts of the same component**
- Tolerance for 45° joint :**                    **0,010" (0.254 mm) for expansion**  
    (Based on frame parts of 2 7/8" wide)
- Tolerance for warpage :**                    **45 1/16" high with middle crosspiece : 9/32"**  
    **\* 50 " high with middle crosspiece : 5/16"**  
    **\* 60 " high with middle crosspiece : 3/8"**  
    (We suggest to use additional hinges or two doors)  
    **Door / Drawer front design #6000 : 1/8"**  
    (if less than 1.5 sq. feet of total surface per component)

N.B.: Our guarantee is applicable for goods returned in original sale condition only. It covers component repair or replacement and shipping only. Guarantee does not cover installation, removal or labor of any kind. Nor does this guarantee cover any product used or installed in connection with our products. This guarantee does not apply to damage resulting from improper handling, alterations, storage, or use in non controlled environment (recommended : 30 to 40 percent humidity) nor does this guarantee cover any joint showing when solid color finishing is used.

CARON reserves the right to make technical improvements or changes on their products and / or their documents without prior notice.

Drawings in this guide and / or any other document are not to scale.

**MAINTENANCE**

- Clean with a moist cloth using a low concentration of soap with water.
- Buff with soft cloth in direction of wood grain.
- Remove any excess moisture with clean dry cloth.
- To reduce warpage, shifting or splitting of wood, avoid sharp changes in temperature and keep relative humidity between 30 % and 40 %.

**The CARON signature confirms that the product complies with the highest standards (quality management system registered under ISO 9001). It also indicates you are part of our reforestation program, giving back to nature... At each 20 doors ordered, we plant a tree. Over 100,000 trees planted since 2005, a premiere in the industry.**





LES INDUSTRIES CARON (MEUBLES) INC.  
45, 4<sup>e</sup> Rue, Montmagny, C.P. 100 (Québec) Canada G5V 3S3  
t. 418.248.0255 f. 418.248.0982  
t. 1.800.463.7060 f. 1.800.463.3656  
caron@caronindustries.com  
caronindustries.com

Thinks wood, thinks **green**  
**caron**®

